

Assembly
and
Operation
of the

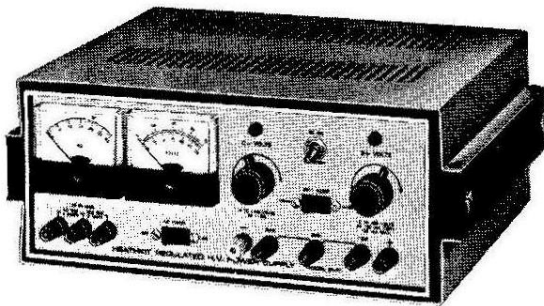

**REGULATED
HIGH VOLTAGE
POWER SUPPLY**

Model IP-17



HEATH COMPANY
BENTON HARBOR, MICHIGAN 49022

TABLE OF CONTENTS

Introduction.	2
Parts List.	3
Step-By-Step Assembly	
Circuit Board Assembly.	4
Mounting Parts On Front Panel.	7
Wiring Front Panel.	10
Mounting Parts On	
Transformer Chassis.	14
Chassis Assembly.	16
Connecting Harness And Transformer	
Leads to Circuit Board.	18
Connecting Harness to Transformer	
Chassis.	19
Mounting Rear Panel.	23
Test And Adjustment.	25
Final Assembly.	27
Operation.	28
Bibliography.	29
In Case Of Difficulty.	30
Circuit Board X-Ray View	
(fold-out from page).	30
Troubleshooting Chart.	31
Specifications.	32
Circuit Description.	34
Chassis Photograph.	36
Replacement Parts Price List.	37
Schematic.(fold-out from page).	39
Warranty	Inside Front Cover
Customer Service	Inside Rear Cover

INTRODUCTION

The Heathkit Model IP-17 Regulated HV (High Voltage) Power Supply is a compact, convenient source of variable regulated high voltage, variable bias voltage, and filament voltage for laboratories and workshops. Separate panel meters are provided for accurate monitoring of the DC output current and voltage. All output binding posts are insulated from the chassis to allow the high (B+) and bias (C-) voltages to be used as either negative or positive voltage sources.

Separate transformers are used for filament and high voltage supplies so the filament circuit may be left on while switching off the high voltage circuit. This eliminates repeated tube warmup time. The dual windings on the transformers can be wired to operate from either 105-125 or 210-250 volts AC.

A meter switch permits you to monitor either the high voltage or the bias voltage on the front panel voltmeter. The special taper C- VOLTS control provides a finer adjustment of low values of bias voltage. Built-in circuit protection prevents damage if the bias voltage output circuit should accidentally be short circuited or overloaded, and the input circuit of the Regulated High Voltage Power Supply is fused for additional protection against overload conditions or short circuits. You will find that all of these features, plus the attractive compact styling, will make this Power Supply a useful and valuable asset on your workbench.

Refer to the "Kit Builders Guide" for complete information on unpacking, parts identification, tools, wiring, soldering, and step-by-step assembly procedures.



PARTS LIST

NOTE: The numbers in parentheses in the Parts List are keyed to the numbers on the Parts Pic-torial (fold-out from Page 5).

To order a replacement part, refer to the "Replacement Parts Price List" and use the Parts Order Form furnished with this kit. If a Parts Order Form is not available, refer to "Replacement Parts" inside the rear cover of the Manual.

PART No.	PARTS Per Kit	DESCRIPTION	PART No.	PARTS Per Kit	DESCRIPTION
RESISTORS			CONTROLS-SWITCHES		
1/2 Watt			(8)10-216	1	50 K Ω control
(1)1-3	2	100 Ω (brown-black-brown)	10-257	1	500 K Ω control
1-9	3	1000 Ω (brown-black-red)	(9)10-162	1	200 K Ω control
1-22	1	22 K Ω (red-red-orange)	(10)10-218	1	500 K Ω miniature control
1-23	2	27 K Ω (red-violet-orange)	(11)60-24	1	SPST rocker switch
1-27	1	150 K Ω 5% (brown-green-yellow)	(12)60-34	1	TPDT rocker switch
1-99	1	240 K Ω 5% (red-yellow-yellow)	(13)61-9	1	SPST toggle switch
1-33	1	470 K Ω (yellow-violet-yellow)	HARDWARE		
1-106	1	680 K Ω 5% (blue-gray-yellow)	#6 Hardware		
1-35	2	1 megohm (brown-black-green)	(14)250-229	8	6-32 x 1/4" phillips head screw
1 and 2 Watt			(15)250-89	19	6-32 x 3/8" screw
1-27-1	1	33 K Ω , 1 watt (orange-orange-orange)	(16)250-270	16	6-32 x 3/8" screw (black)
1-14-2	2	1500 Ω , 2 watt (brown-green-red)	(17)250-26	4	6-32 x 5/8" screw
1-6-2	4	27 K Ω , 2 watt (red-violet-orange)	(18)250-227	4	6-32 x 7/8" phillips head screw
1/2 Watt Precision			(19)250-535	4	6-32 decorative screw
(2)2-86	1	150 K Ω	(20)250-365	4	#6 x 1/4" sheet metal screw
2-138	1	400 K Ω	(21)250-304	4	6-32 x 7/16" spacer stud
CAPACITORS			(22)252-3	35	6-32 nut
Electrolytic			(23)254-1	29	#6 lockwasher
(3)25-270	1	2 x 20 μ fd, 350 V	(24)259-1	8	#6 solder lug
(4)25-182	2	70 μ fd, 350 V	(25)255-15	4	#6 x 1/2" spacer
25-158	2	20 μ fd, 450 V	#8 Hardware		
25-183	1	40 μ fd, 450 V	(26)250-137	16	8-32 x 3/8" screw
Other Capacitors			(27)252-4	16	8-32 nut
(5)23-59	1	.05 μ fd tubular	(28)254-2	16	#8 lockwasher
(6)27-37	1	.056 μ fd Mylar*	(29)259-2	1	#8 solder lug
(7)27-34	1	.2 μ fd Mylar*	(30)259-24	2	#8 wire clamp
			Other Hardware		
			(31)252-7	2	Control nut
			(32)253-10	2	Control flat washer
			(33)254-4	2	Control lockwasher
			(34)252-32	2	Push-on speednut
			(35)207-37	2	Tube retainer
			(36)259-20	25	Circuit board terminal

*Mylar - Registered Trademark, Du Pont.



PART No.	PARTS Per Kit	DESCRIPTION
----------	---------------	-------------

TUBES-DIODES-LAMPS

411-8	2	6L6GC tube
411-59	2	OA2 tube
411-64	1	6X4 tube
411-95	1	6BH6 tube
(37)57-27	6	Silicon diode
(38)412-15	2	NE-2H lamp

TERMINAL STRIPS-SOCKETS

(39)431-14	1	2-lug terminal strip
(40)431-51	1	2-lug terminal strip
431-35	1	7-lug terminal strip
(41)434-129	4	7-pin socket
(42)434-58	2	8-pin socket

BINDING POSTS-KNOBS

(43)100-16-2	3	Black binding post cap
100-16-18	1	Red binding post cap
100-534	1	White binding post cap
100-641	3	Brown binding post cap
(44)427-3	8	Binding post base
(45)75-17	6	Binding post insulator
(46)462-245	2	Knob
(47)455-50	2	Knob bushing

METAL PARTS

(48)210-35	1	Bezel
(49)90-357-2	2	Cabinet half-shell
(50)200-488	1	Transformer chassis
(51)200-489	1	Circuit board chassis
(52)203-482-1	1	Front panel
(53)203-483-1	1	Rear panel
(54)204-759-1	4	End cap
(55)204-776-1	2	Siderail

PART No.	PARTS Per Kit	DESCRIPTION
----------	---------------	-------------

METERS-TRANSFORMERS

407-123	1	Voltmeter
407-124	1	Milliammeter
54-184	1	Filament transformer
54-185	1	Power transformer

HARNESS-WIRE-SLEEVING

134-155	1	Wiring harness
89-23	1	Line cord
344-50	1	Black hookup wire
344-52	1	Red hookup wire
344-56	1	Blue hookup wire
346-1	1	Sleeving

MISCELLANEOUS

(56)73-45	5	Grommet
(57)75-30	1	Strain relief*
75-71	1	Strain relief
85-174-1	1	Circuit board
(58)207-5	2	Cable clamp
(59)211-34	2	Handle strap
(60)261-28	4	Plastic foot
(61)261-30	2	Line cord retainer
(62)413-10	1	Red lens
413-14	1	Amber lens
421-25	1	1.5 ampere slow-blow fuse
(63)422-1	1	Fuseholder
490-5	1	Nut starter
597-308	1	Kit Builders Guide
597-260	1	Parts order form
391-34	1	Blue and white identification label
	1	Manual (see front cover for part number)
		Solder

*This strain relief is supplied for use in areas, mainly outside of the U.S.A., where 2-wire or 3-wire round line cords are required.

STEP-BY-STEP ASSEMBLY

CIRCUIT BOARD ASSEMBLY

Before starting to assemble the circuit board, be sure you have read the wiring, soldering, and step-by-step assembly information in the Kit Builders Guide.

Position all parts as shown in the Pictorials. Follow the instructions carefully, and read the entire step before performing the operation. Use 1/2 watt resistors unless directed other-

wise in a step. All resistors will be called out by the resistance value (in Ω , $K\Omega$, or megohms); the color code will also be given for color coded resistors. Capacitors will be called out by the capacitance value and type.

Perform each step in the order listed and complete each Pictorial before proceeding to the next Pictorial. When the circuit board is finished, set it aside until it is called for later on in the assembly instructions.

START ↓

() Locate the circuit board and position it lettered side up as shown.

NOTE: When installing diodes, the cathode end must be positioned as shown on the screened side of the circuit board. The cathode end is marked with either a color end, color dot, color band or a symbol.

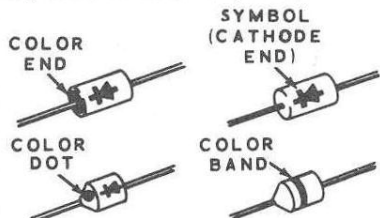

() Install the six silicon diodes as shown.

() Check to be sure the six diodes are installed correctly. Then solder their leads to the foils and clip off excess lead lengths.

() 1000 Ω (brown-black-red).

() 100 Ω (brown-black-brown).

() 100 Ω (brown-black-brown).

() 1000 Ω (brown-black-red).

() 1000 Ω (brown-black-red).

() 470 KΩ (yellow-violet-yellow).

() Solder all leads to the circuit board foil and cut off the excess lead lengths.

Remove 1/4" of insulation from each end of two 11" blue wires. Twist these blue wires together to form a twisted pair as shown below.



() Connect the twisted pair from holes D and D to holes U and U. Solder the four wire ends to the circuit board foil and cut off the excess lead lengths.

() Position the twisted pair as shown on the Pictorial.

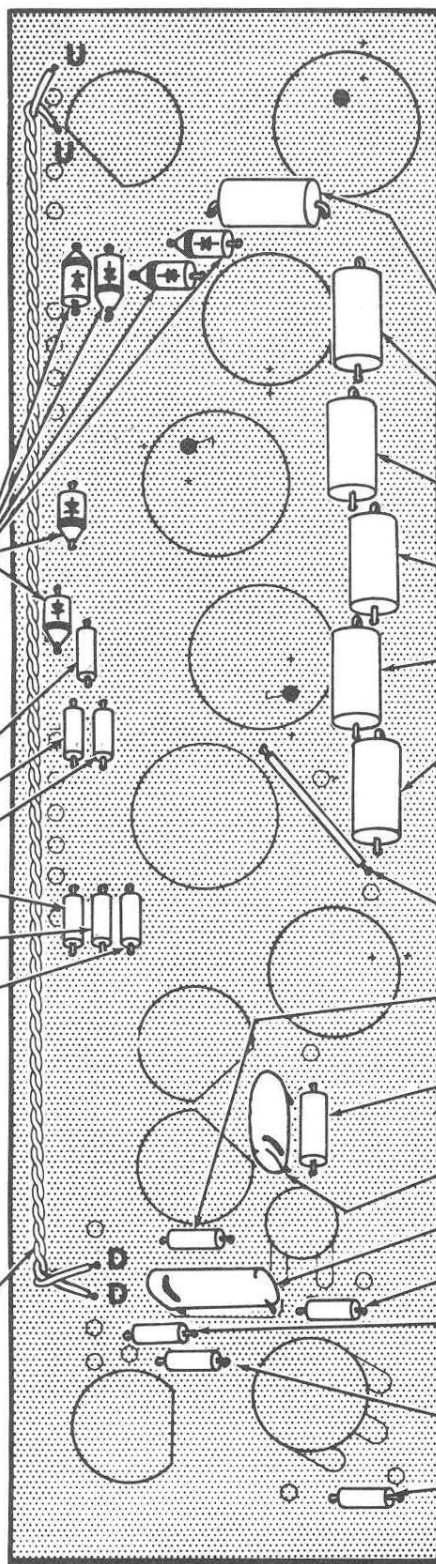

CONTINUE ↓

() 1500 Ω, 2 watt (brown-green-red).

() 1500 Ω, 2 watt (brown-green-red).

() 27 KΩ, 2 watt (red-violet-orange).

() 27 KΩ, 2 watt (red-violet-orange).

() 27 KΩ, 2 watt (red-violet-orange).

() 27 KΩ, 2 watt (red-violet-orange).

() Solder all leads to the foils and clip off the excess lead lengths.

() 1-3/4" blue wire. Remove 1/4" of insulation from each end of the wire and install as shown.

() 1 megohm (brown-black-green).

() 33 KΩ, 1 watt (orange-orange-orange).

() .2 μfd Mylar. Position the banded end as shown.

() .056 Mylar. Position the banded end as shown.

() 680 KΩ (blue-gray-yellow).

() 150 KΩ (brown-green-yellow). NOTE: Do not use the 1/2 watt precision resistor here.

() 1 megohm (brown-black-green).

() 240 KΩ (red-yellow-yellow).

() Solder all leads to the foil and clip off the excess lead lengths.

PICTORIAL 1

Proceed to Pictorial 2.

START



NOTE: When soldering the 7-pin tube sockets to the circuit board foil, the first application of solder will tend to run into the socket pin. Allow this first application to cool; then again apply solder to the connection. Use only enough heat to allow the solder to flow.

() Cut off the shield tab on each of the four 7-pin tube sockets, then install one of these sockets at V4. Solder all socket pins that connect to a circuit board foil. Do not solder any pins that do not connect to a foil on the circuit board.

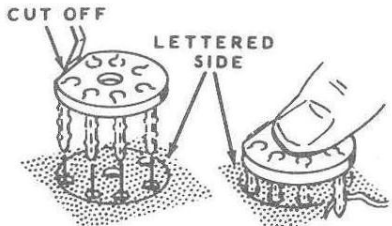

ALIGN ALL PINS TO THEIR RESPECTIVE HOLES. PRESS THE SOCKET DOWN UNTIL IT SEATS IN PLACE.

NOTE: In a like manner, install 7-pin tube sockets in the following steps. Solder all socket pins that connect to a circuit board foil.

() 7-pin tube socket at V2.

() 7-pin tube socket at V1.

() 7-pin tube socket at V3.

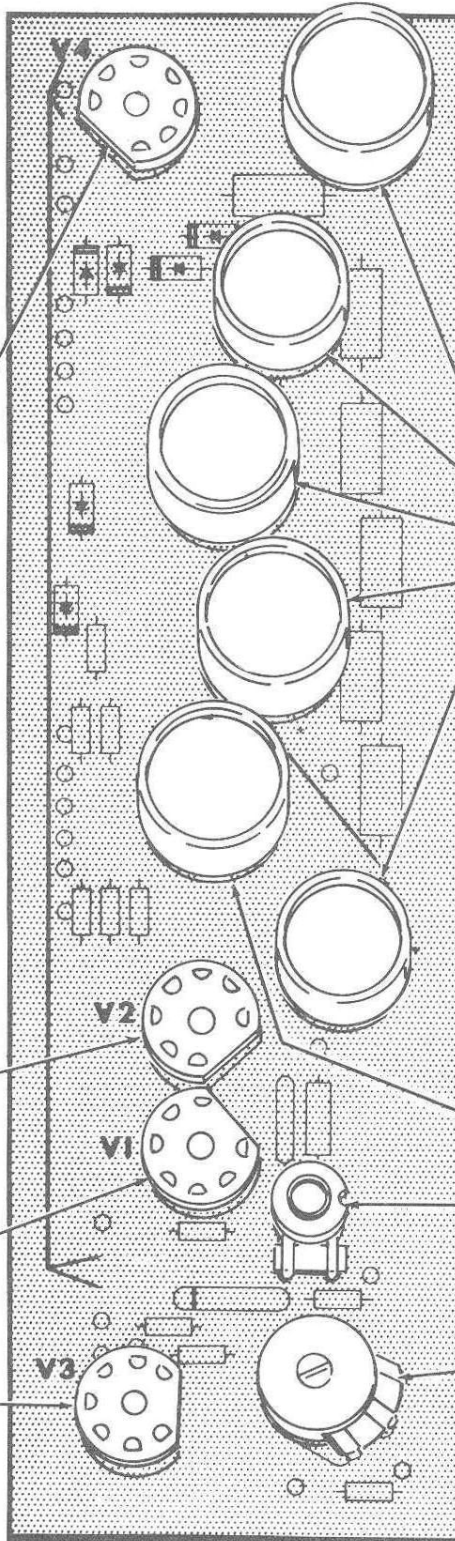

CONTINUE



NOTE: Solder the connections of each of the following parts as it is installed. Then clip off excess lead lengths.

CAUTION: One lead of an electrolytic capacitor will have a + mark or a red dot which must be matched with the same mark on the circuit board.

() 40 μ f electrolytic.

() 20 μ f electrolytic.

() 70 μ f electrolytic.

() 70 μ f electrolytic.

() 20 μ f electrolytic.

() 2 x 20 μ f electrolytic. **NOTE:** Two of the leads on this capacitor are marked with a red dot.

() 500 K Ω control.

() 200 K Ω control.

The circuit board will be mounted later. Put it aside for the present.

FINISH

PICTORIAL 2

Proceed to Pictorial 3.



MOUNTING PARTS ON FRONT PANEL

Refer to Pictorial 3 for the following steps.

NOTE: A plastic nut starter is supplied with this kit. Use this nut starter to hold and start 6-32 and 3-48 nuts on screws. Refer to Page 3 of the Kit Builders Guide for further information.

- () Place the front panel on a soft cloth in the position shown in the Pictorial.

NOTE: When you install the binding post bases in the following steps, be sure the hole through each binding post base is in a vertical position.

- () Refer to part 1 of Detail 3A, and install a binding post base at BJ. Use two binding post insulators, a #6 lockwasher, two 6-32 nuts, and a #6 solder lug. Be sure the binding post insulators are seated within the mounting hole, and position the solder lug as shown in the Pictorial.
- () In a like manner, install binding post bases at locations BK, BL, BN, BP, BS, BT, and BU.

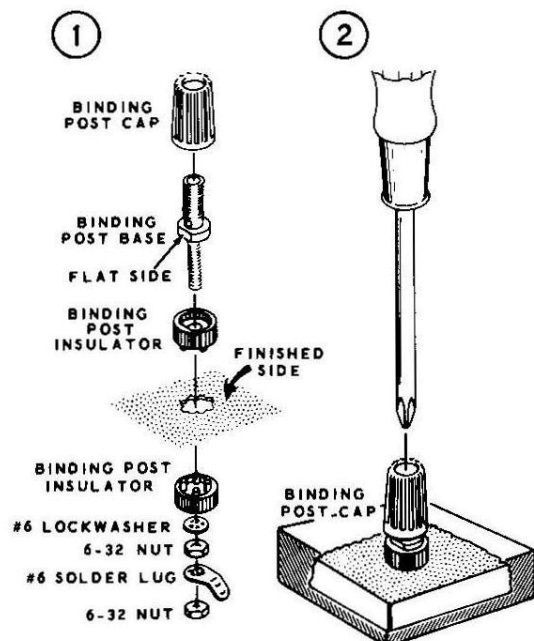

Detail 3A

Place a colored binding post cap on each binding post as follows: Tighten each cap finger-tight.

- () Red cap on binding post BJ.
- () Black caps on binding posts BK, BL, and BN.
- () White cap on binding post BP.
- () Brown caps on binding posts BS, BT, and BU.

NOTE: In the following steps, use a phillips screwdriver to expand the end of the binding post base so the cap will not come off of the binding post. The screwdriver blade must be large enough so it will not go inside of the binding post base.

- () Refer to Detail 3A and place the tip of a large phillips screwdriver through the opening in the end of each binding post cap and against the hollow end of the binding post base. Support the binding post base with a block of wood to avoid bending the panel.
- () Now tap the handle end of the phillips screwdriver sharply with a small hammer to expand the hollow end of the binding post base. The binding post base should be expanded only enough to prevent the caps from coming off of the binding posts base.
- () Refer to Detail 3B, and mount the SPST rocker switch (#60-24) at BR with 6-32 x 7/8" phillips head screws and #6 x 1/2" spacers as shown. Note the position of lug 1.

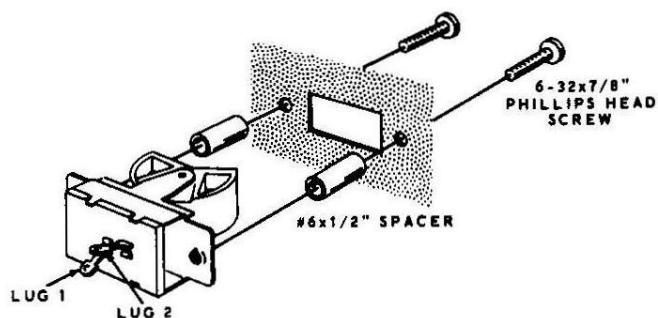

Detail 3B

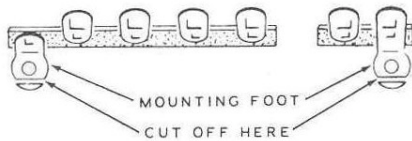
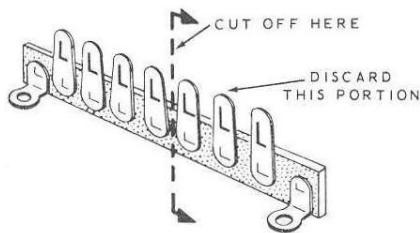

Detail 3C

- () Locate the 7-lug and the 2-lug terminal strips. Prepare these terminal strips in the following steps as shown in Detail 3C.
- () Refer to part 1 of Detail 3C. Use diagonal cutters and cut off the right end of the 7-lug terminal strip at the location shown. The 4-lug section will be used. Discard the 3-lug section.
- () Refer to part 2 of Detail 3C. Use diagonal cutters and cut off a small portion of the mounting foot on both the 2-lug and the 4-lug terminal strips. CAUTION: Do not cut into the hole in either mounting foot.

NOTE: Two terminal strips and the TPDT rocker switch will be mounted in the next step.

- () Refer to Detail 3D, and mount the TPDT switch (#60-34) at location BF with a 4-lug terminal strip at BE, and a 2-lug terminal strip at BG. Use #6 x 1/2" spacers, #6 lockwashers and 6-32 x 7/8" phillips head screws. Position the terminal strips as shown in the Pictorial. Bend the two outside rows of switch lugs outward about 10 degrees.

- () Refer to Detail 3E, and mount the 500 K Ω control (#10-257) at BD. Use a control lockwasher, a control flat washer, and a control nut. Position the control as shown in Pictorial 3.

- () In a like manner, mount the 50 K Ω control (#10-216) at BH.

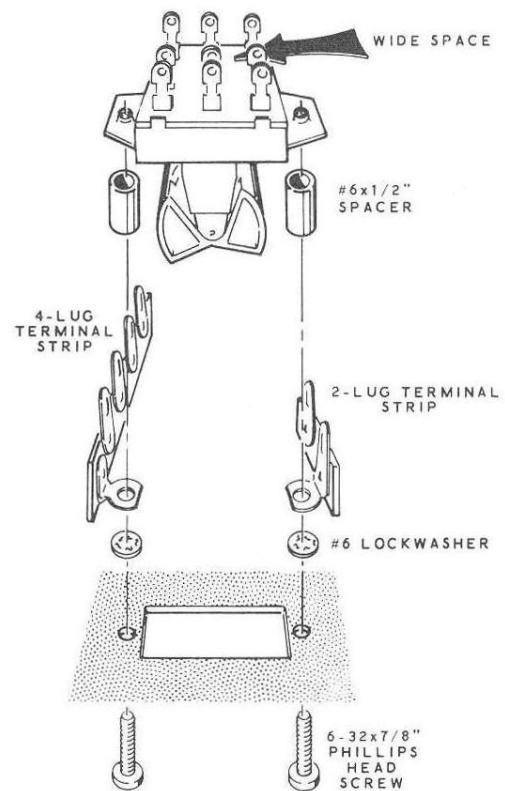

Detail 3D

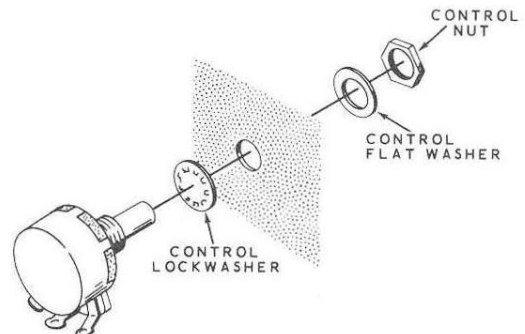

Detail 3E

- () Locate the SPST toggle switch (#61-9) and remove one of the switch nuts and the switch lockwasher. Then, refer to Detail 3F and position the remaining switch nut 3/16" from the end of the switch bushing.

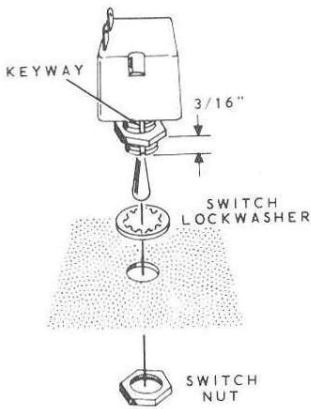

Detail 3F

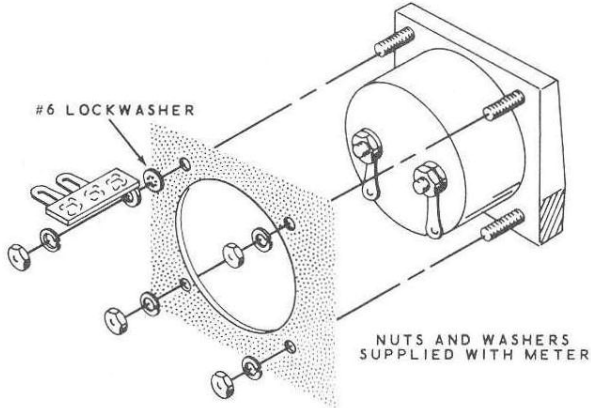

Detail 3H

- () Mount the switch at BB, using the switch lockwasher and other switch nut. Position the switch with its keyway toward the bottom of the panel. One of the lugs may be in the center position instead of being on the end as shown.
- () Refer to Detail 3G, and install a red lens at BA with a push-on speednut. Place the speednut on the slotted end of the lens as shown; then hold the lens and press the speednut firmly against the panel.

- () Refer to Detail 3H, and mount the voltmeter (#407-123) at BY. Use the hardware supplied with the meter. Also use a #6 lockwasher and 2-lug terminal strip at BX as shown in the Detail. Do not overtighten the meter mounting nuts.
- () Mount the milliammeter (#407-124) at BZ with the hardware supplied with the meter. No terminal strip is used with this meter.
- () Cut one or more pieces of cardboard large enough to cover both meter faces. (The meter cartons may contain this material.) Then fasten the cardboard over the meter faces with tape or rubber bands as shown in Detail 3J. This will protect the meter faces during kit assembly.

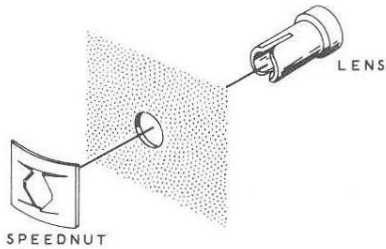

Detail 3G

- () In a like manner, install an amber lens at BC.

CAUTION: Handle the meters very carefully when you perform the following steps. The meter cases can be damaged and their faces scratched very easily.

NOTE: There may be a shorting wire between the two terminals on either meter. If so, remove the shorting wire as soon as you have installed the meters in the following steps.

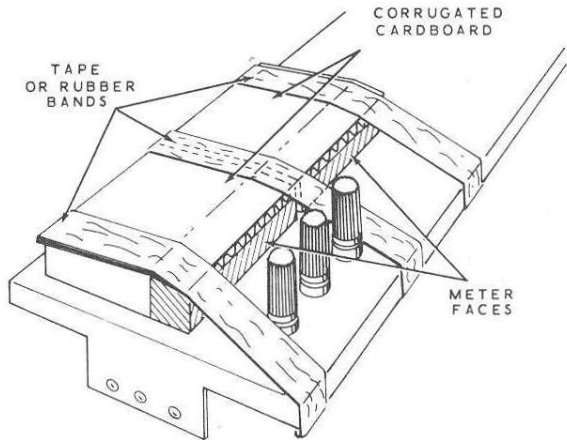

Detail 3J

WIRING FRONT PANEL

Refer to Pictorial 4 (fold-out from Page 6) for the following steps.

NOTE: When wiring this kit you will be instructed to prepare lengths of hookup wire ahead of time, as in the following step. To prepare a wire, cut it to the indicated length and remove 1/4" of insulation from each end. The wires are listed in the order in which they will be used.

- () Prepare the following lengths of hookup wire:

<u>COLOR</u>	<u>LENGTH</u>
Black	3-3/4"
Black	2-1/2"
Black	1-3/4"
Black	1-1/2"
Black	1-1/4"
Black	8"
Black	2-1/2"
Blue	5"

- () Connect a 3-3/4" black wire from binding post BK (NS) to binding post BN (NS).
- () Connect a 2-1/2" black wire from binding post BK (S-2) to lug 4 of switch BF (NS).
- () Connect a 1-3/4" black wire between lug 4 (S-2) and lug 9 (S-1) of switch BF. Position the wire as shown in the Pictorial.
- () Connect a 1-1/2" black wire from lug 3 of control BH (S-1) to binding post BN (NS).
- () Connect a 1-1/4" black wire from lug 2 of switch BF (S-1) to lug 2 of switch BB (NS).
- () Connect an 8" black wire from lug 2 of switch BB (S-2) to lug 1 of switch BR (NS).
- () Connect a 2-1/2" black wire from binding post BL (S-1) to lug 2 of terminal strip BG (S-1).
- () Connect a 5" blue wire from lug 4 of terminal strip BE (NS) to binding post BP (NS).

- () Prepare the following lengths of hookup wire:

<u>COLOR</u>	<u>LENGTH</u>
Black	8"
Red	8"
Black	7"
Blue	7"

- () Refer to Detail 4A, and prepare a twisted pair using the 8" black and 8" red wires.

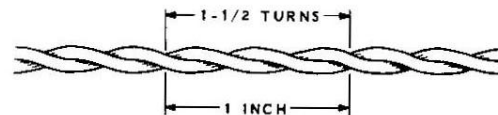

Detail 4A

- () At one end of the twisted pair, connect the red wire to lug 5 (S-1) and the black wire to lug 8 (NS) of switch BF.
- () At the other end of this twisted pair, connect the red wire to the solder lug on the positive (+) post of meter BY (S-1). Connect the black wire to the solder lug on the negative (-) post of meter BY (S-1).
- () Prepare another twisted pair using the 7" black and 7" blue wires.
- () At one end of this twisted pair, connect the blue wire to lug 2 (NS) and the black wire to lug 3 (NS) of terminal strip BE.
- () At the other end of this twisted pair, connect the black wire to lug 1 (NS) and the blue wire to lug 2 (NS) of terminal strip BX. Position the twisted pair as shown in Pictorial 4.
- () Insert a neon lamp (#412-15) into the amber lens at BC. Then place a 1" length of sleeving on each lead of the lamp.
- () Connect either neon lamp lead to lug 1 (S-2) and the other lead to lug 2 (S-2) of terminal strip BX.

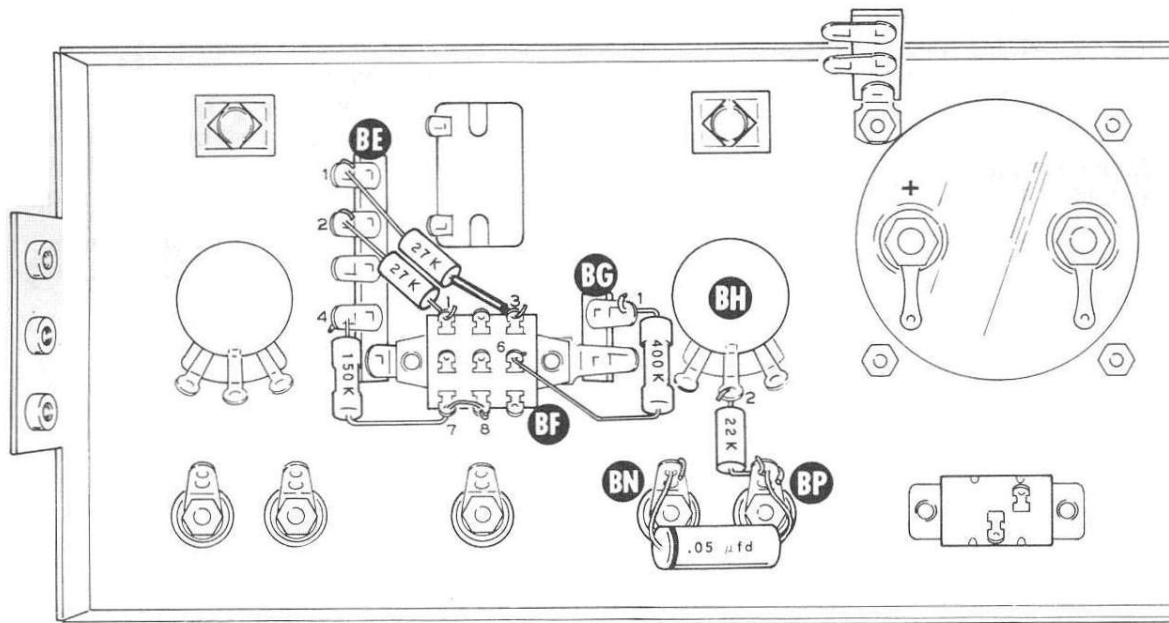

PICTORIAL 5

- () Insert a neon lamp into the red lens at BA. Then place a 1-1/4" length of sleeving on one lead of this lamp.
- () Connect this lead to lug 3 of terminal strip BE (NS).
- () Place a 1" length of sleeving on the other lead of the lamp, and connect this lead to lug 1 of terminal strip BE (NS).

Refer to Pictorial 5 for the following steps.

- () Place a 3/4" length of sleeving on one lead of a 27 K Ω (red-violet-orange) resistor and connect this lead to lug 3 of switch BF (S-1). Connect the other lead of the resistor to lug 1 of terminal strip BE (S-2).
- () Connect a 27 K Ω (red-violet-orange) resistor from lug 2 of terminal strip BE (S-2) to lug 1 of switch BF (S-1).

NOTE: Where a wire passes through a connection and then goes to another point, as in the next step, it will count as two wires in the solder instructions (S-2), one entering and one leaving the connection.

- () Connect one lead of a 150 K Ω precision resistor to lug 4 of terminal strip BE (S-2). Insert the other lead through lug 7 (S-2) to lug 8 (S-2) of switch BF.
- () Connect a 400 K Ω precision resistor from lug 1 of terminal strip BG (NS) to lug 6 of switch BF (S-1).
- () Connect a 22 K Ω (red-red-orange) resistor from lug 2 of control BH (S-1) to binding post BP (NS).
- () Connect the lead at the marked (banded) end of a .05 μ fd tubular capacitor to binding post BN (NS). Connect the other lead of the capacitor to binding post BP (S-3).

Connecting Wiring Harness To Front Panel

- () Locate the wiring harness (#134-155). Then shape and position it as shown in Detail 6A.

NOTE: There are eight numbered wire breakouts from the wiring harness. These breakouts will

be called BO#1, BO#6, etc., in the steps that follow.

- () At BO#6, cut off the white-gray wire and the white-orange wire 2-1/2" from the breakout. Then remove 1/4" of insulation from the end of each of these two wires. Save the two cut off wires; they will be used later.

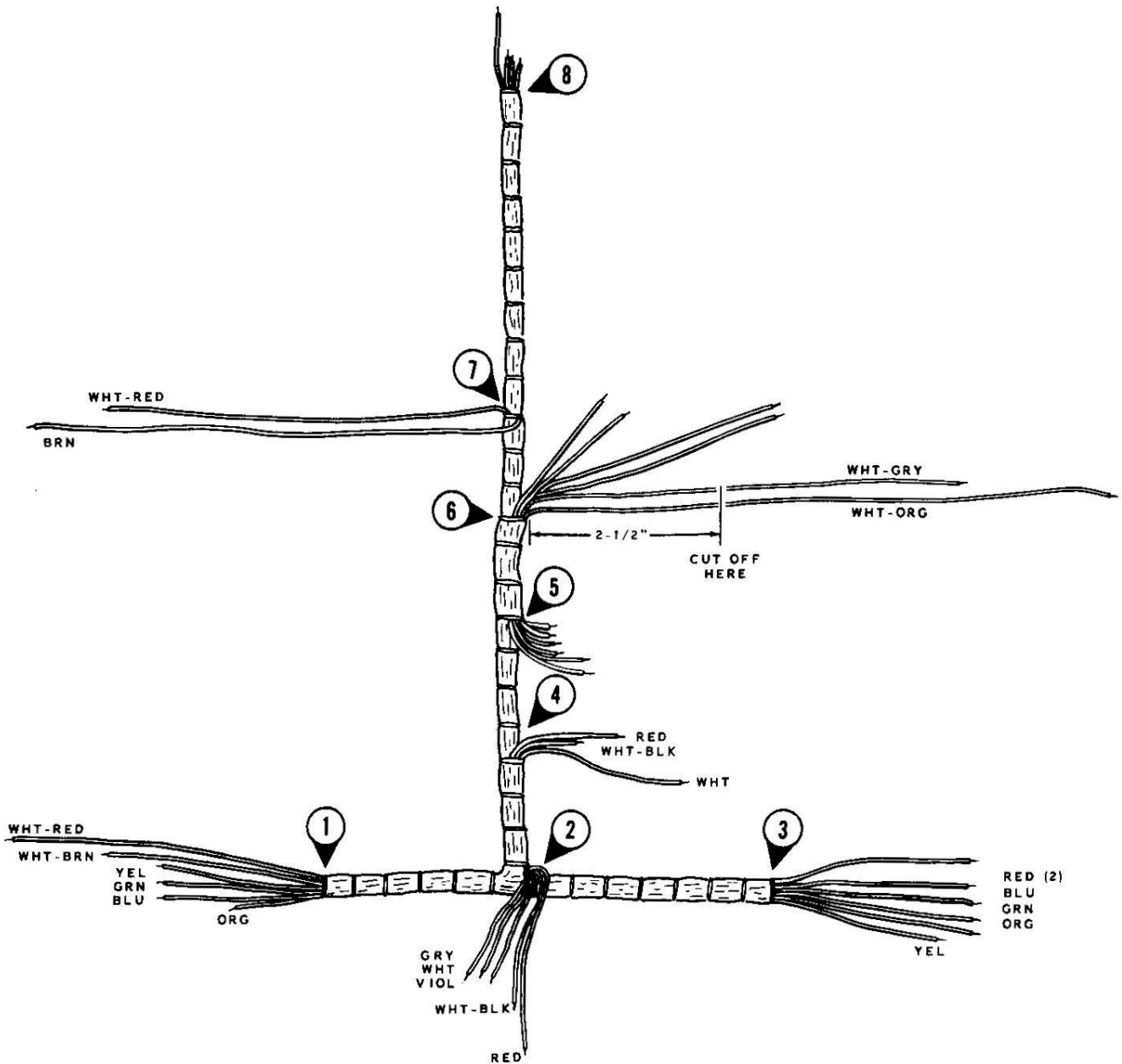

Detail 6A

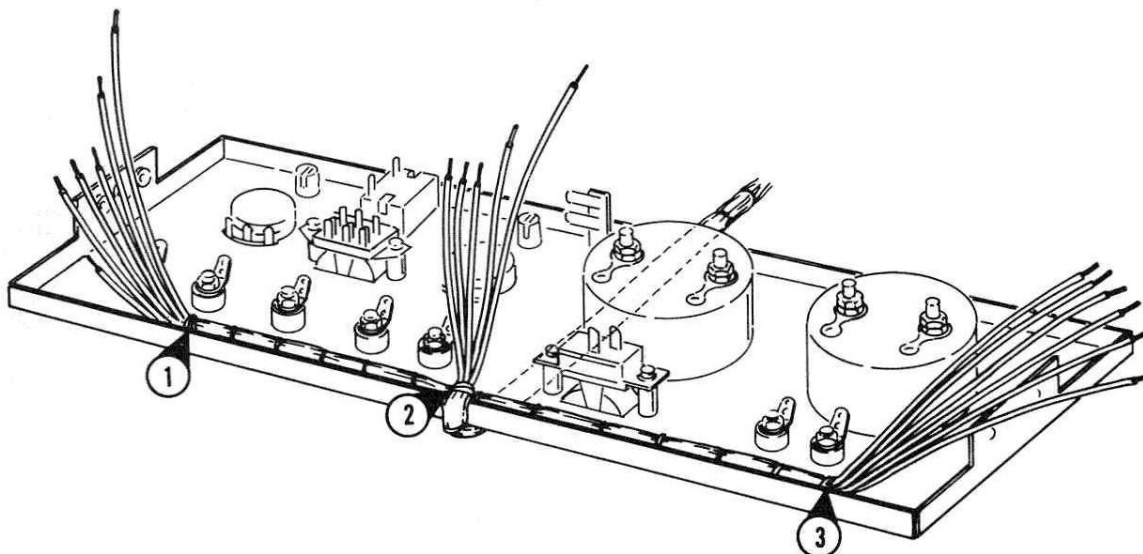

Detail 6B

- () Refer to Detail 6B, and position the wiring harness along the inside edge at the bottom of the front panel. Press the harness down against the inside of the panel between the binding posts and the turned-up flange on the bottom edge of the panel.
- () Now hold the harness in place at BO #2 and bend the free end of the harness down and under the front panel. This will keep the remainder of the harness out of your way while you make the connections to the front panel.

Refer to Pictorial 6 (fold-out from Page 17) for the following steps. Position each wire as shown in the Pictorial as you make the connection.

Connect the wires from BO #2 as follows:

- () Violet to lug 1 of switch BR (S-2).
- () Gray to lug 2 of switch BR (S-1).
- () White-black to binding post BN (S-4).
- () White to lug 1 of control BH (S-1).
- () Red to lug 1 of terminal strip BG (S-2).

Connect the wires from BO #1 as follows:

- () White-red to lug 1 of switch BB (S-1).
- () White-brown to lug 3 of terminal strip BE (S-3).
- () Green to lug 3 of control BD (S-1).
- () Blue to lug 2 of control BD (S-1).
- () Yellow to lug 1 of control BD (S-1).
- () Orange to binding post BJ (S-1).

Connect the wires from BO #3 as follows:

- () Both red to the solder lug on the positive (+) post of meter BZ (S-2).
- () Orange to the solder lug on the negative (-) post of meter BZ (S-1).

Set the front panel aside for now. It will be mounted later.

MOUNTING PARTS ON TRANSFORMER CHASSIS

Refer to Pictorial 7 (fold-out from Page 17) for the following steps.

- () Locate the transformer chassis. Then refer to Detail 7A and install plastic grommets in holes CA, CB, CD, and CC. Insert the grommets from the inside of the chassis. Do not separate the two sections of the grommet.
- () Similarly, install a plastic grommet from the outside of the chassis at CG.

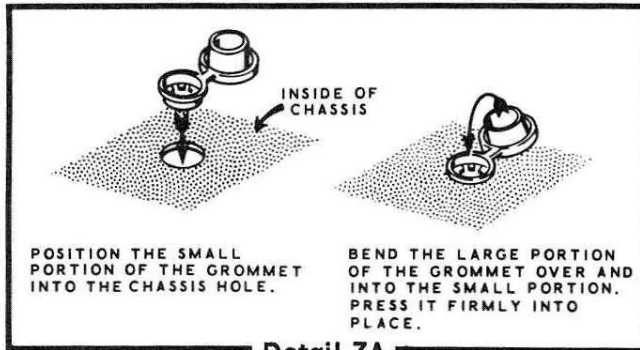

NOTE: When hardware is called for in a step, only the screw size will be given. For instance, "6-32 x 3/8" hardware" means that a 6-32 x 3/8" screw, one or more #6 lockwashers, and a 6-32 nut should be used. The Detail referred to in the step will show the proper number and position of lockwashers to use.

- () Refer to Detail 7B, and mount 8-pin sockets at V5 and V6. Use a tube retainer and 6-32 x 3/8" hardware. Mount each socket on the outside of the chassis. Position the keyway in the socket as shown by the arrows on the Pictorial. **NOTE:** Do not use the 6-32 x 3/8" black screws until called for in a step.
- () Position the chassis as shown in Detail 7C; then mount filament transformer #54-184 at T2 with 8-32 x 3/8" hardware. Use a #8 solder lug at location CJ in place of a #8 lockwasher. Be sure the transformer terminal lugs are positioned as shown.
- () Insert the leads from the transformer through grommet CC for connection later.

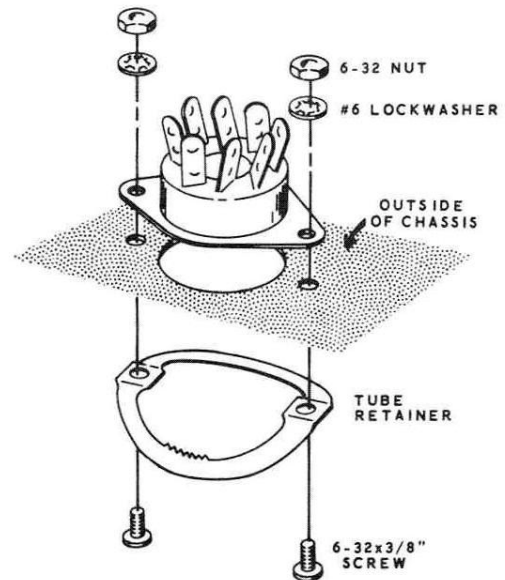

Detail 7B

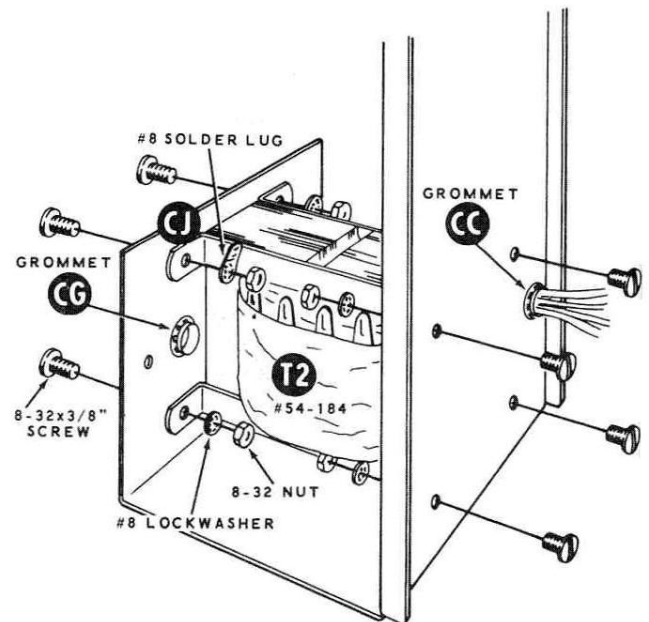

Detail 7C

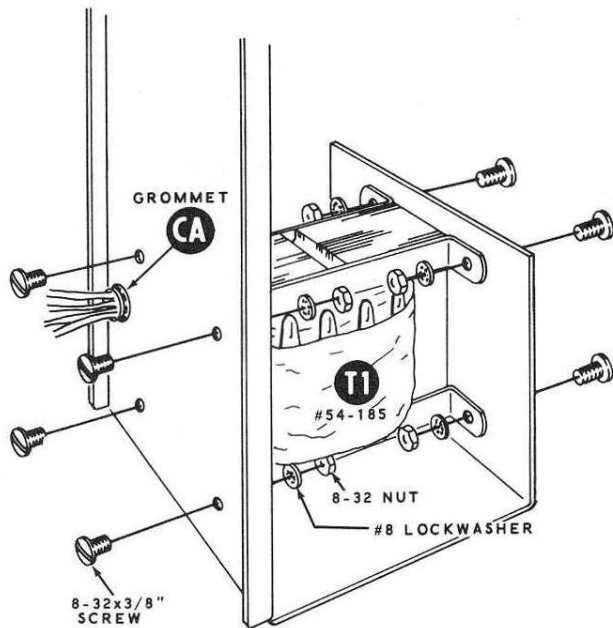

Detail 7D

- () Position the chassis as shown in Detail 7D; then mount power transformer #54-185 at T1 with 8-32 x 3/8" hardware. Be sure the transformer terminal lugs are positioned as shown.
- () Insert the leads from this transformer through grommet CA for connection later.
- () Refer to Detail 7E, and mount a fuseholder at CH with 6-32 x 3/8" hardware.

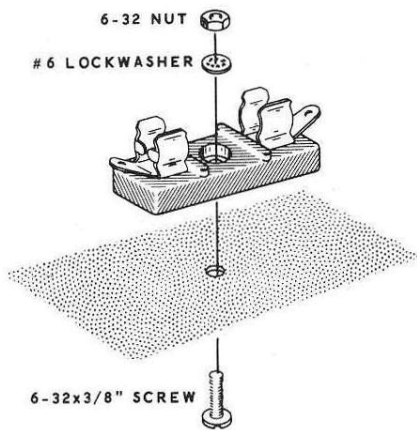

Detail 7E

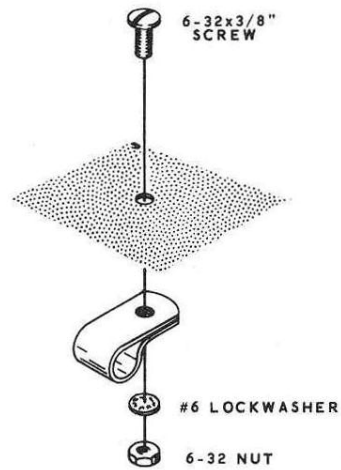

Detail 7F

- () Refer to Detail 7F, and mount cable clamps at CE and CF with 6-32 x 3/8" hardware. Position the cable clamps as shown in Pictorial 7.
- () Locate the length of white-gray and white-orange wires that were previously cut off of the wiring harness.
- () Remove 1/4" of insulation from the unstripped end of the white-gray wire. Then connect this wire from lug 3 of tube socket V5 (S-1) to lug 3 of tube socket V6 (NS).
- () Cut the white-orange wire into two equal lengths (approximately 4-1/2" long). Remove 1/4" of insulation from the unstripped end of the white-orange wire that already has the insulation removed from one end.
- () Connect this white-orange wire from lug 2 of socket V5 (S-1) to lug 2 of socket V6 (NS).
- () Remove 1/2" of insulation from each end of the remaining white-orange wire.

- () Insert either end of the white-orange wire through lug 8 (NS) to lug 7 (S-1) of tube socket V5.
- () Insert the other end of this wire through lug 7 (S-2) to lug 8 (NS) of tube socket V6.
- () Connect either yellow lead coming from grommet CC to lug 8 of tube socket V6 (S-2).
- () Connect the other yellow lead coming from grommet CC to lug 2 of tube socket V6 (S-2).
- () Position both yellow leads flat against the chassis as shown in the Pictorial.
- () Locate a cabinet siderail and position it so the end of the rail with the four wide spaced holes line up with the four holes in the end of the transformer chassis.
- () Secure the siderail to the transformer chassis with four 6-32 x 3/8" black screws as shown.
- () In a like manner, secure the other siderail to the other end of the transformer chassis with four 6-32 x 3/8" black screws.
- () Locate the circuit board and bend the blue twisted pair of wires straight up and away from the circuit board.

CHASSIS ASSEMBLY

Refer to Pictorial 8 for the following steps.

- () Place the transformer chassis on your work surface. Position the opening in the chassis away from you and the fuseholder down toward your work surface.
- () Place the circuit board foil side up on the circuit board chassis with the 400 VOLT ADJUST control positioned as shown in Detail 8A. Be careful not to pinch the blue twisted pair of wires between the chassis and the circuit board.

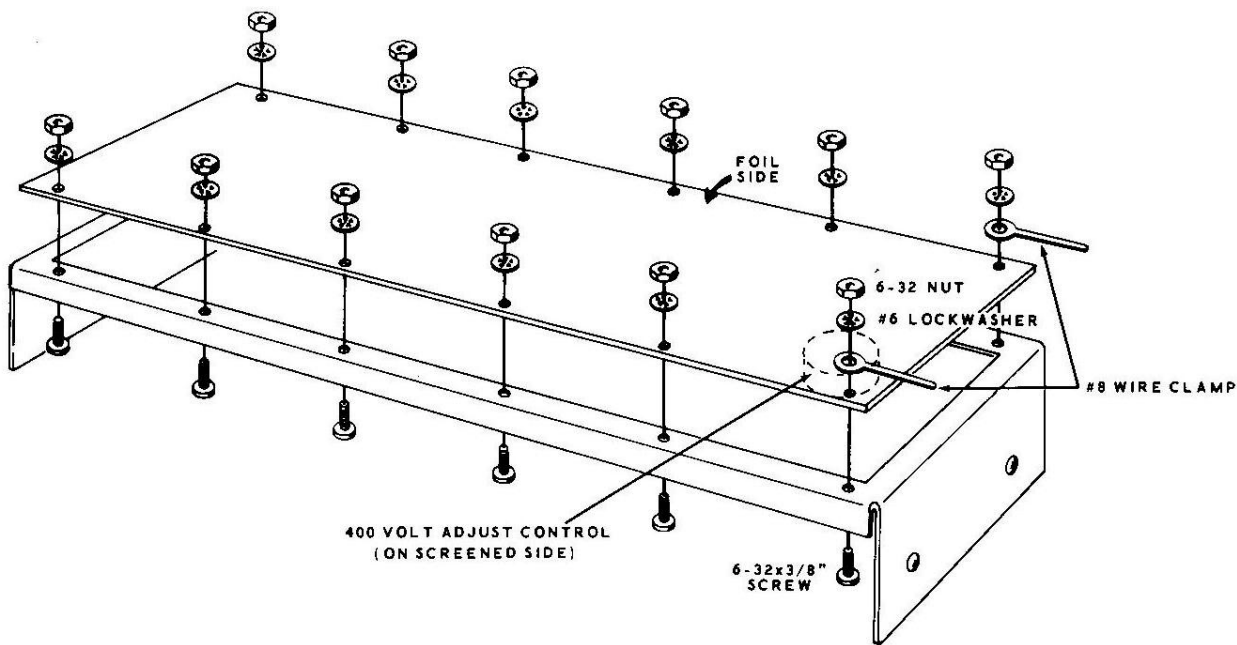

Detail 8A

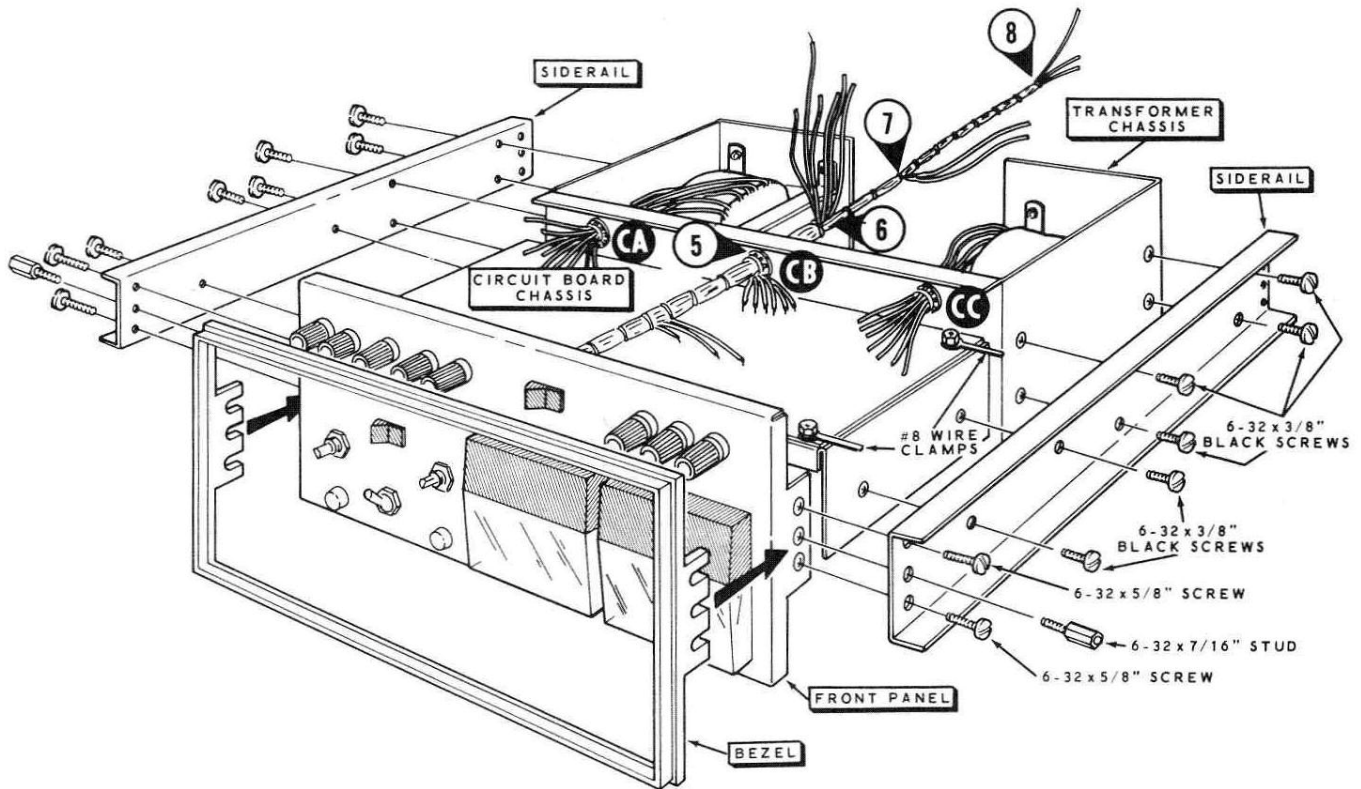

PICTORIAL 8

- () Secure the circuit board to the circuit board chassis with 6-32 x 3/8" hardware at the 12 locations shown. Install the two #8 wire clamps at the locations shown in the Detail.
- () Place the circuit board chassis between the siderails as shown in Pictorial 8. Then secure the siderails to the circuit board chassis with 6-32 x 3/8" black screws through the two indicated holes in each siderail.
- () Locate the front panel and remove the protective cardboard from the meter faces. Then carefully bend the wiring harness until it extends straight out from the inside surface of the panel.
- () Insert breakouts #8, #7, and #6 of the wiring harness through grommet CB until the wires at BO #5 are at the grommet.
- () Position the front panel so the three mounting holes at each end of the front panel line up with the three holes in the end of each siderail.
- () Start a 6-32 x 7/16" spacer stud into the center hole at each end of the front panel. Turn the spacer studs in only a few turns.
- () Place the bezel over the front panel and seat it firmly in place. Then tighten the spacer studs finger-tight.
- () Now secure the siderails to the front panel with 6-32 x 5/8" screws at the four locations shown and securely tighten the spacer studs.
- () You may wish to place tape on the top and bottom edges of the bezel to prevent scratching these surfaces of the bezel.

CONNECTING HARNESS AND TRANSFORMER LEADS TO CIRCUIT BOARD

Refer to Pictorial 9 for the following steps.

- () Position the Power Supply as shown in the Pictorial.
- () Carefully examine the lugs of switch BR and make sure they do not touch the metal circuit board chassis. Bend these lugs, if necessary, away from the chassis.
- () Locate the strip of circuit board connectors and cut off 23 connectors as shown in part 1 of Detail 9A.

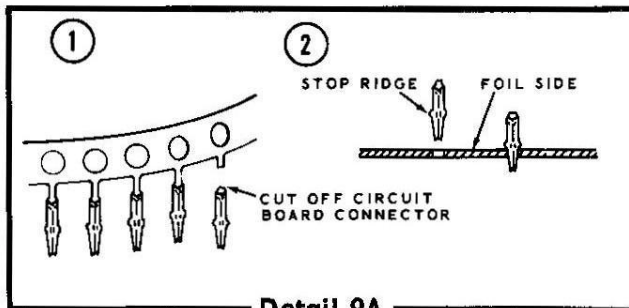

Detail 9A

- () Refer to part 2 of Detail 9A and insert a connector, from the foil side of the circuit board, into each of the 23 lettered locations shown in Pictorial 9.

NOTE: When you perform the soldering operation in each of the following steps, be sure the circuit board connector is soldered to the foil and that the wire is securely soldered in the connector.

Connect the transformer leads that come from grommet CA to the circuit board connectors as follows:

- () Either red to W (S-1).
- () Other red to T (S-1).
- () Red-yellow to S (S-1).
- () Either blue to R (S-1).
- () Other blue to P (S-1).
- () Either white to N (S-1).
- () Other white to M (S-1).

Connect the harness wires from BO#5 (grommet CB) to the circuit board connectors as follows:

- () White-orange to L (S-1).
- () White-yellow to K (S-1).
- () White-green to J (S-1).
- () White-blue to H (S-1).
- () White-violet to G (S-1).
- () White-gray to F (S-1).

Connect the harness wires coming from BO#4 to the circuit board as follows:

- () White-black to Y (S-1).
- () Red to Z (S-1).
- () White to AA (S-1).

Connect the transformer leads coming from grommet CC to the circuit board as follows:

- () Either white to E (S-1).
- () Other white to C (S-1).
- () Either blue to B (S-1).
- () Other blue to A (S-1).
- () Position the green, gray, and green-yellow transformer leads coming from grommet CC along the left edge of the circuit board. Then wrap the two #8 wire clamps at the left-hand corners of the circuit board around these three transformer leads to hold them in position as shown in Pictorial 9.
- () Connect these three transformer leads as follows:
 - () Green-yellow to binding post BU (S-1).
 - () Green to binding post BT (S-1).
 - () Gray to binding post BS (S-1).

- () Pull any excess lengths of the transformer leads back through grommets CA and CC toward the transformers.

Connect the harness wires from BO #3 to the circuit board as follows:

- () Green to AB (S-1).
- () Yellow to AC (S-1).
- () Blue to AD (S-1).

This completes the wiring to the circuit board and the front panel.

CONNECTING HARNESS TO TRANSFORMER CHASSIS

Refer to Pictorial 10 for the following steps.

- () Bend the free end of the wiring harness and insert the wires from BO #6 through grommet CD. These wires will be connected later.

- () Twist together the brown and white-red wires coming from BO #7 and insert them through cable clamp CE.

- () Connect the white-red wire to lug 1 (NS) and the brown wire to lug 4 (NS) of transformer T1. Position the wires as shown.

Insert the free end of the wiring harness through cable clamp CF. Then connect the wires from BO #8 as follows:

- () Violet to lug 1 of transformer T2 (NS).
- () White-brown to lug 2 of transformer T2 (NS).
- () Brown to lug 4 of transformer T2 (NS).
- () Connect the gray wire to lug 1 of fuseholder CH (S-1).
- () Position the wiring harness as shown.

NOTE: Transformers T1 and T2 each have dual primary windings and may be wired for operation on either 115 VAC or 230 VAC. Perform only the group of steps that applies to the line voltage in your area.

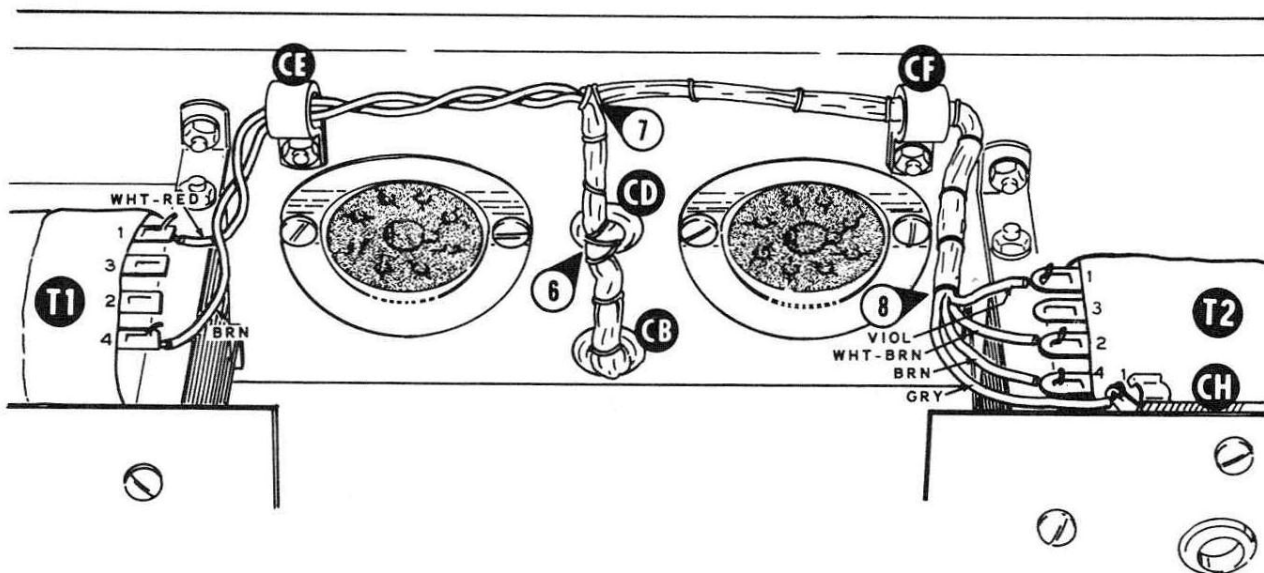

PICTORIAL 10

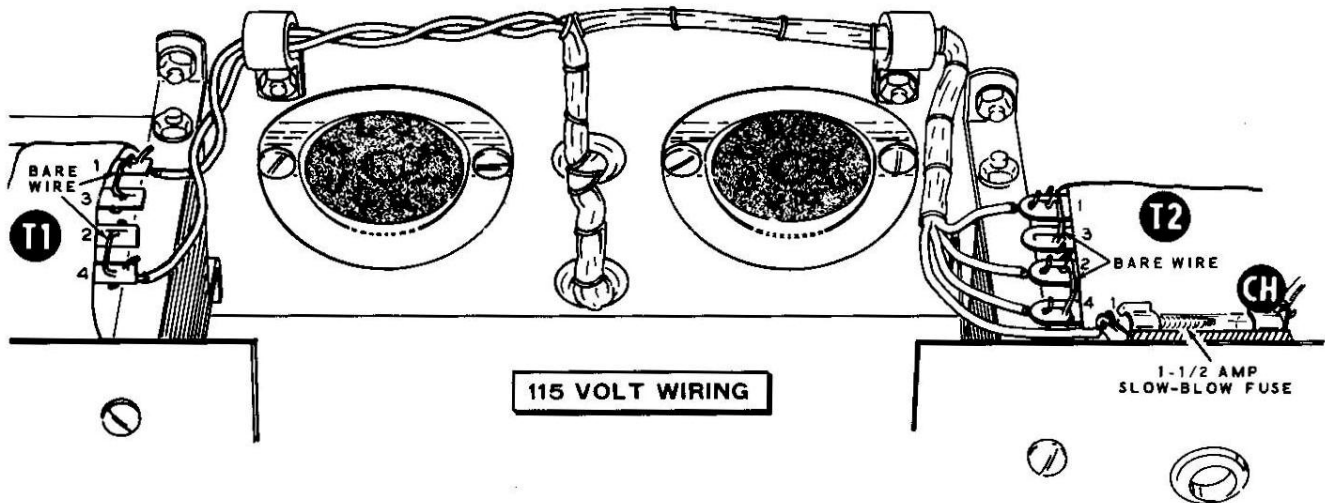

Detail 10A

Wiring For 115 Volt Operation

Refer to Detail 10A for the following steps.

- () Remove the insulation from a 3" length of black hookup wire. Then cut this bare wire into four 3/4" lengths for use in the following steps.
- () Connect a 3/4" bare wire between lug 1 (S-2) and lug 3 (S-1) of transformer T1.
- () Connect a 3/4" bare wire between lug 2 (S-1) and lug 4 (S-2) of transformer T1.
- () Connect a 3/4" bare wire between lug 1 (S-2) and lug 3 (S-1) of transformer T2.
- () Connect a 3/4" bare wire between lug 2 (S-2) and lug 4 (NS) of transformer T2.
- () Install the 1-1/2 ampere slow-blow fuse in fuseholder CH.
- () Now turn to Page 22 and perform the steps under "Connecting Harness Wires From Breakout #6".

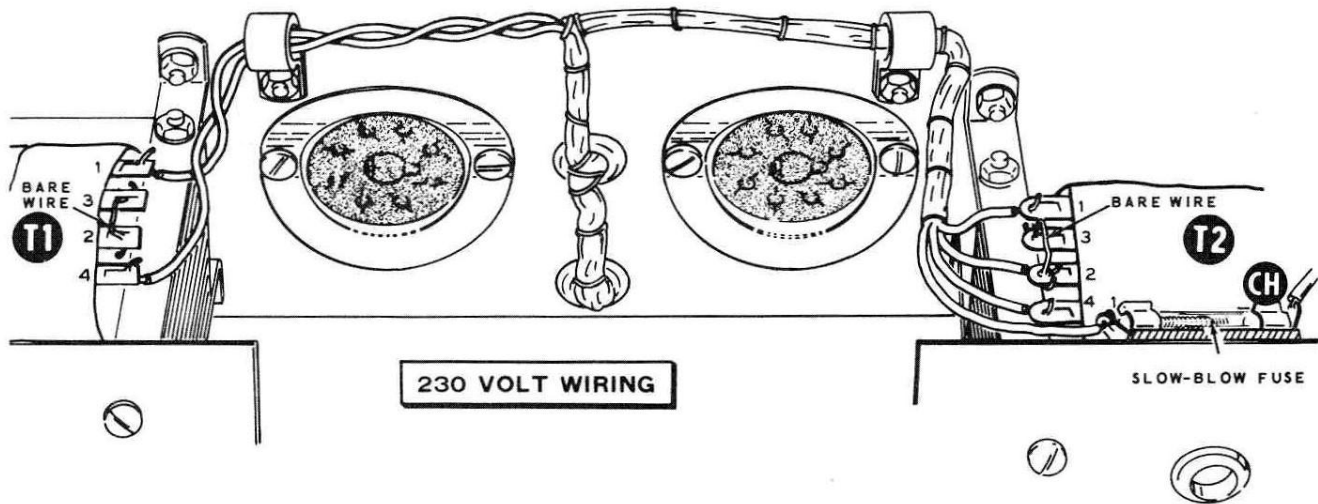

Detail 10B

Wiring For 230 Volt Operation

Refer to Detail 10B for the following steps.

- () Remove the insulation from a 1-1/2" length of black hookup wire. Then cut this bare wire into two 3/4" lengths for use in the next two steps.
- () Connect a 3/4" bare wire between lug 2 (S-1) and lug 3 (S-1) of transformer T1.
- () Connect a 3/4" bare wire between lug 2 (S-2) and lug 3 (S-1) of transformer T2.

- () Solder the connections on lugs 1 (S-1) and 4 (S-1) of transformer T1 and lug 1 (S-1) of transformer T2.

NOTE: The 1-1/2 ampere slow-blow fuse that is supplied with this kit is the correct value for 105-125 VAC operation. If your kit is to be operated from a 210-250 VAC source, a 1 ampere slow-blow fuse (not supplied) should be used.

- () Install this slow-blow fuse in fuseholder CH.

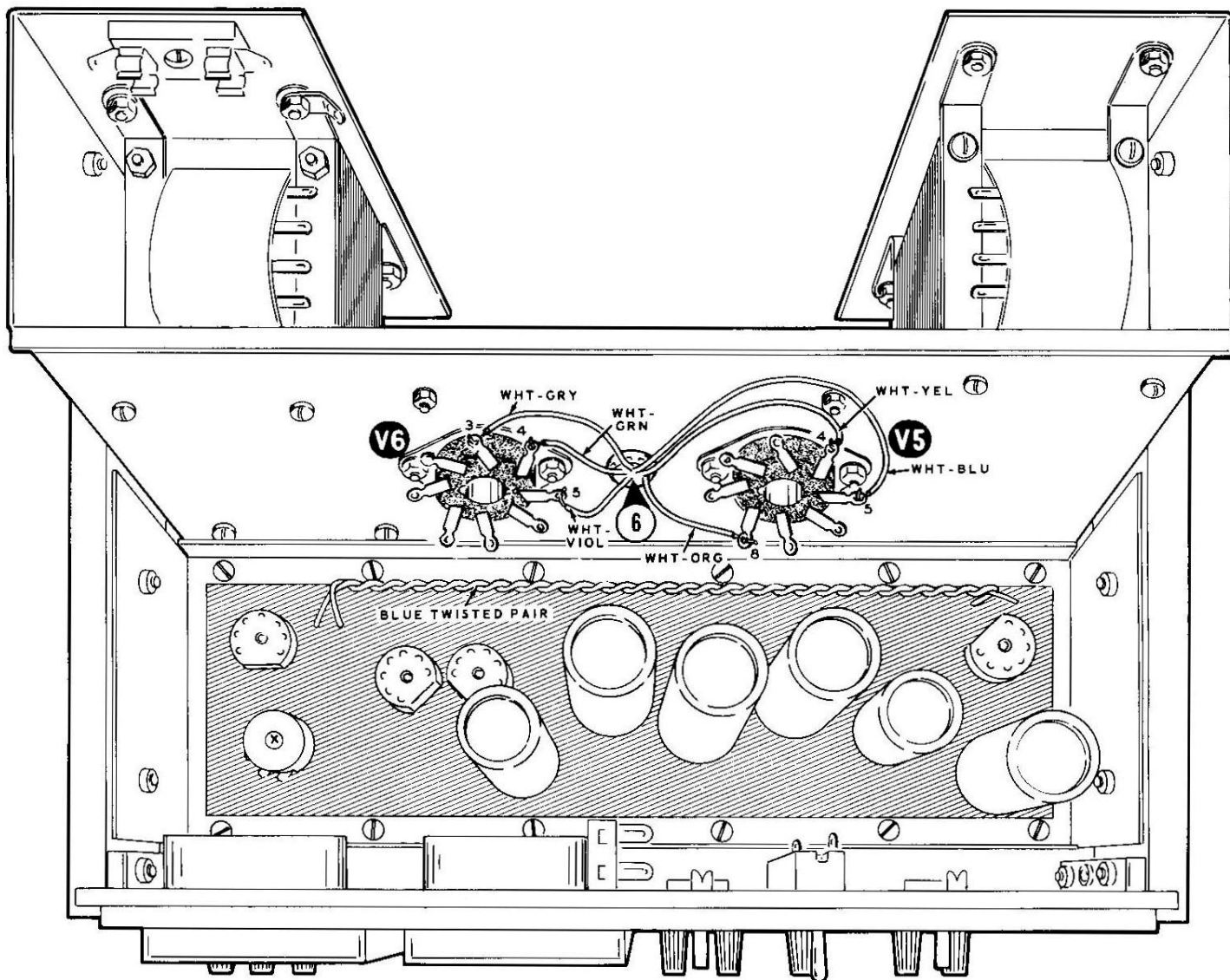

PICTORIAL 11

Connecting Harness Wires From Breakout #6

Refer to Pictorial 11 for the following steps.

Connect the wires coming from BO #6 as follows:

- () White-gray to lug 3 of tube socket V6 (S-2).
- () White-green to lug 4 of tube socket V6 (S-1).
- () White-violet to lug 5 of tube socket V6 (S-1).
- () White-orange to lug 8 of tube socket V5 (S-3).
- () White-blue to lug 5 of tube socket V5 (S-1).
- () White-yellow to lug 4 of tube socket V5 (S-1).
- () Position the blue twisted pair down along the edge of the circuit board as shown in the Pictorial. **CAUTION:** Be sure you do not puncture the insulation on the blue wires.

MOUNTING REAR PANEL

Refer to Pictorial 12 (fold-out from Page 22) for the following steps.

- () Mount a line cord retainer with two #6 x 1/4" sheet metal screws at each of the two locations shown.
- () Refer to part 1 of Detail 12A, and separate the leads at the end of the line cord for approximately 2" as shown.

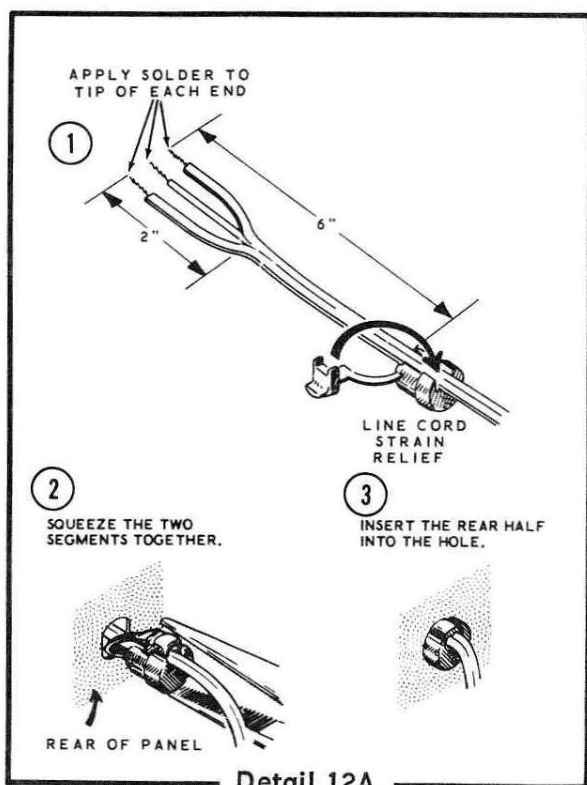

- () Twist together the fine wire strands at the end of each line cord lead and apply a small amount of solder to the tip of each lead.

NOTE: The line cord strain relief that you will install in the following steps will depend on which line cord you use. If you use the flat 3-wire cord supplied with this kit, install strain relief #75-71. If you are using a round line cord (not supplied with this kit), install strain relief #75-30.

- () Place the strain relief on the line cord 6" from the prepared end.
- () Refer to parts 2 and 3 of Detail 12A, and insert the line cord and strain relief into the hole in the rear panel.
- () Insert the free end of the line cord through grommet CG and place the rear panel in position between the end of each siderail.
- () Secure each siderail to the rear panel with a 6-32 x 7/16" spacer stud and two 6-32 x 3/8" black screws at the locations shown in each siderail.
- () Carefully peel away the paper backing from the blue and white identification label. Then press the label onto the chassis at the location shown in Pictorial 12. Be sure to refer to the numbers on this label in any communications with the Heath Company about this kit.

NOTE: A flat 3-conductor line cord is supplied with this kit. One of its outer leads is marked with a ridge in the insulation along its edge. The other outer lead is unmarked. The third lead is color coded green.

Refer to the inset drawing on Pictorial 12 and connect the line cord leads as follows.

- () Unmarked lead to lug 2 of fuseholder CH (S-1).
- () Ridged lead to lug 4 of transformer T2 [(S-3 if wired for 115 volt operation; (S-2) if wired for 230 volt operation)].
- () Green lead to solder lug CJ (S-1).

Installing Control Knobs

The knobs supplied with this kit use knob bushings that provide permanent positive action without the use of setscrews.

In the following steps you will install knobs on the two control shafts as shown in Detail 12B. Perform these steps carefully, since it is difficult to remove a bushing from a knob once it is fully inserted.

- () Place a knob bushing on each of the two control shafts; the spring tab on the bushing should face outward.
- () Turn each control shaft to its full counter-clockwise position.
- () Press knobs firmly onto the control bushings with the pointers at the 7 o'clock position.
- () Remove the knobs with the bushings still inserted in them; then drive the bushings into the knobs. Use a nutdriver or other appropriate size tool as shown in part 2 of Detail 12B.
- () Reinstall the knobs on the control shafts as shown in part 3 of Detail 12B.

This completes the assembly of your Heathkit Regulated High Voltage Power Supply. Carefully inspect all connections for loose wires or unsoldered joints. Remove any wire clippings or solder splashes that may be lodged in the wiring. Do not install the tubes until you are instructed to do so. Proceed to the Test and Adjustment section that follows.

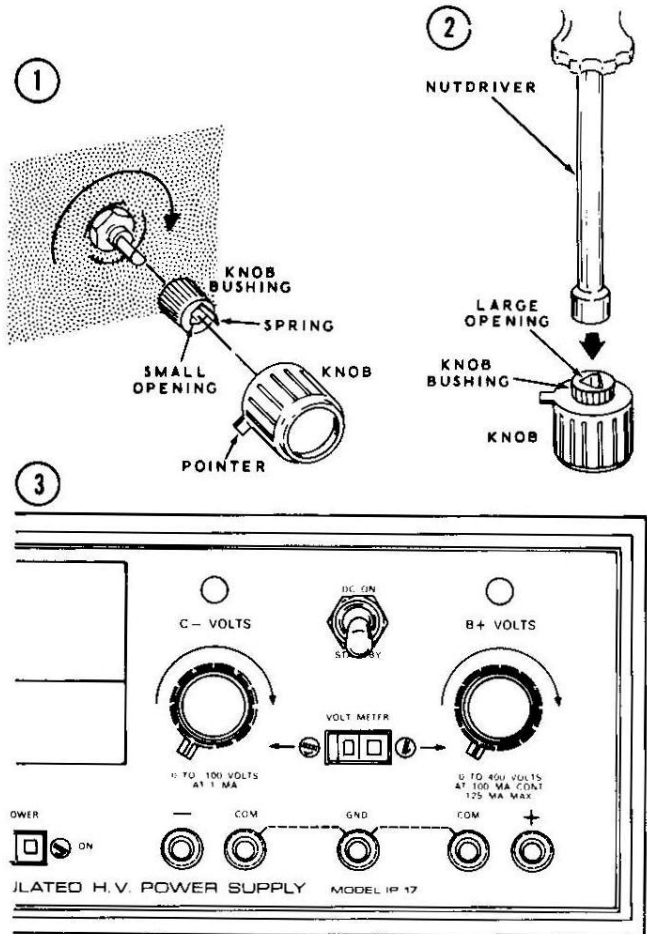

Detail 12B

TEST AND ADJUSTMENT

Before applying power to your Regulated High Voltage Power Supply, we suggest that you check for possible short circuits or wiring errors with an ohmmeter. If an ohmmeter is not available, perform the steps under Adjustments on this page.

OHMMETER TESTS

Refer to Figure 1 (fold-out from Page 27) for the following tests.

NOTE: In most ohmmeters the common (black) test lead is connected to the negative terminal of the battery in the ohmmeter. However, in some ohmmeters the common test lead is connected to the positive terminal of the internal battery. This difference in polarity of the test leads between ohmmeters will affect the resistance readings obtained in the following steps. Try reversing the ohmmeter test leads if the resistance reading does not check correctly the first time. If the reading is incorrect even after you reverse the test leads, refer to the In Case Of Difficulty section of the Manual.

Screen Voltage Supply Circuit

- () Place the Power Supply on your work surface as shown. Turn the ohmmeter on and set its ohmmeter range switch to the R x 10K position.
- () Check the resistance from lug 8 to lug 4 of tube socket V6. The ohmmeter should first indicate a fairly low value of resistance. Then the resistance reading should slowly increase to at least 500 K Ω . If a resistance reading of less than 500 K Ω is obtained, check to be sure diodes D1 and D2 are installed with their cathode ends in the proper position as shown on the screened side of the circuit board.

High Voltage Supply Circuit

- () Check the resistance from lug 3 of tube socket V6 to either common (COM) binding post. A resistance reading of at least 300 K Ω should be obtained. If the resistance reading is less than 300 K Ω , check to make sure the two 70 μ fd capacitors (C2 and C3) are installed properly on the circuit board.

Bias Voltage Supply Circuit

- () Check the resistance from lug 7 of tube socket V1 to either common (COM) binding post. This resistance reading should be at least 50 K Ω . If this reading is less than 50 K Ω , refer to the In Case Of Difficulty section of the Manual.

Output Binding Post Circuits

- () Check the resistance between the red positive (+) binding post and either common (COM) binding post. The resistance should be at least 100 K Ω .

ADJUSTMENTS

Refer to Figure 1 (fold-out from Page 27) for the following steps.

Remove the tubes from their cartons and install them as follows. Support the circuit board while you insert the tubes in their sockets.

- () 6BH6 tube in tube socket V3.
- () OA2 tubes in sockets V1 and V2.
- () 6X4 tube in socket V4.
- () 6L6GC tubes in sockets V5 and V6.

Be sure each 6L6GC tube is pressed firmly into its socket and that the tube retainer securely grips the base of the tube. If it does not, bend the retainer upward, away from the chassis.

- () Place the AC POWER switch in the OFF position.
- () Place the DC ON - STANDBY switch in the STANDBY position.
- () Turn the C-VOLTS and the B+ VOLTS controls fully counterclockwise.
- () Place the VOLTMETER switch in the B+ VOLTS position.
- () Check the position of the meter pointers. Carefully turn the slotted adjustment screw in the front of the meter until the pointers are at the zero (0) mark on the scale.
- () From the top of the circuit board, use a screwdriver and turn the ZERO VOLTAGE ADJUST control fully counterclockwise.



- () In a like manner, turn the 400 VOLT ADJUST control fully clockwise.

NOTE: If you do not obtain the correct results, as stated in the following steps, refer to the In Case of Difficulty section on Page 30 of this Manual.

- () Insert the line cord plug into a convenient 50/60 Hz AC outlet and place the AC POWER switch in the ON position. Be sure the DC ON-STANDBY switch is in the STANDBY position.
- () The red lamp on the front panel and the filaments of tubes V3, V4, V5, and V6 should light.
- () Allow several minutes for the filaments in the tubes to reach normal operating temperatures. Then place the DC ON-STANDBY switch in the DC ON position.
- () Voltage regulator tubes V1 and V2 should now glow faintly and the VOLTS meter pointer should indicate upscale from zero, or slightly to the right of the zero point on the scale.
- () The MILLIAMPERES meter should indicate zero current since there is no load connected to the B+ output circuit of the Power Supply.

NOTE: The adjustment of the ZERO VOLTAGE ADJUST and the 400 VOLT ADJUST controls interact with each other. Repeat the adjustments in the following four steps several times so that when the B+ VOLTS control is fully clockwise,

the VOLTS meter reads at the 400 mark on the scale. The VOLTS meter should read at the zero mark on the scale when the B+ VOLTS control is fully counterclockwise.

- () Turn the B+ VOLTS control fully counterclockwise.
- () Adjust the ZERO VOLTAGE ADJUST control on the top of the circuit board until the VOLTS meter indicates zero volts.
- () Turn the B+ VOLTS control fully clockwise.
- () Adjust the 400 VOLT ADJUST control on the top of the circuit board until the VOLTS meter reads 400 volts.
- () Repeat the four steps just performed until the VOLTS meter indicates zero with the B+ VOLTS control turned fully counterclockwise, and 400 volts with the B+ VOLTS control turned fully clockwise.
- () Place the VOLTMETER switch in the C-VOLTS position. The amber lamp on the front panel should now light.
- () Turn the C-VOLTS control through its full left to right rotation. The VOLTS meter should indicate zero volts with the C-VOLTS control turned fully counterclockwise and well above 100 volts with the control turned fully clockwise.

This completes the tests and adjustments of the Regulated H.V. Power Supply. Disconnect the line cord plug from the AC outlet.

FINAL ASSEMBLY

Refer to Pictorial 13 for the following steps.

- () Wrap the line cord around the line cord retainers on the rear panel of the Power Supply.
- () Locate one of the cabinet half-shells and the four rubber feet.
- () Carefully remove the backing paper from a plastic foot and position it on the bottom of the cabinet half-shell as shown in the Pictorial. Press the foot firmly into place.
- () In a like manner, mount the three remaining plastic feet at the locations shown on the Pictorial.
- () If you had placed tape on the edges of the bezel, remove it at this time.
- () Place the Power Supply upside down on your work surface. Position the cabinet half-shell so the angled edge of the half-shell is toward the front of the Power Supply; then place it over the bottom of the Power Supply.

Secure the half-shell to the siderails with 6-32 x 1/4" phillips screws at the four locations shown in the Pictorial.

- () Place the Power Supply in its normal upright position and mount the other cabinet half-shell over the top of the Power Supply. Secure the half-shell to the siderails with 6-32 x 1/4" phillips screws.
- () Remove the tape from each end of one of the handles. Place the handle, grained side out, over the spacer studs in either one of the siderails.
- () Place an end cap over each end of the handle and siderail. Secure each cap with a 6-32 decorative head screw as shown in the Pictorial. Use a coin to tighten the decorative head screws.
- () In a like manner, install the remaining handle on the other siderail.

This completes the assembly of your Regulated High Voltage Power Supply.

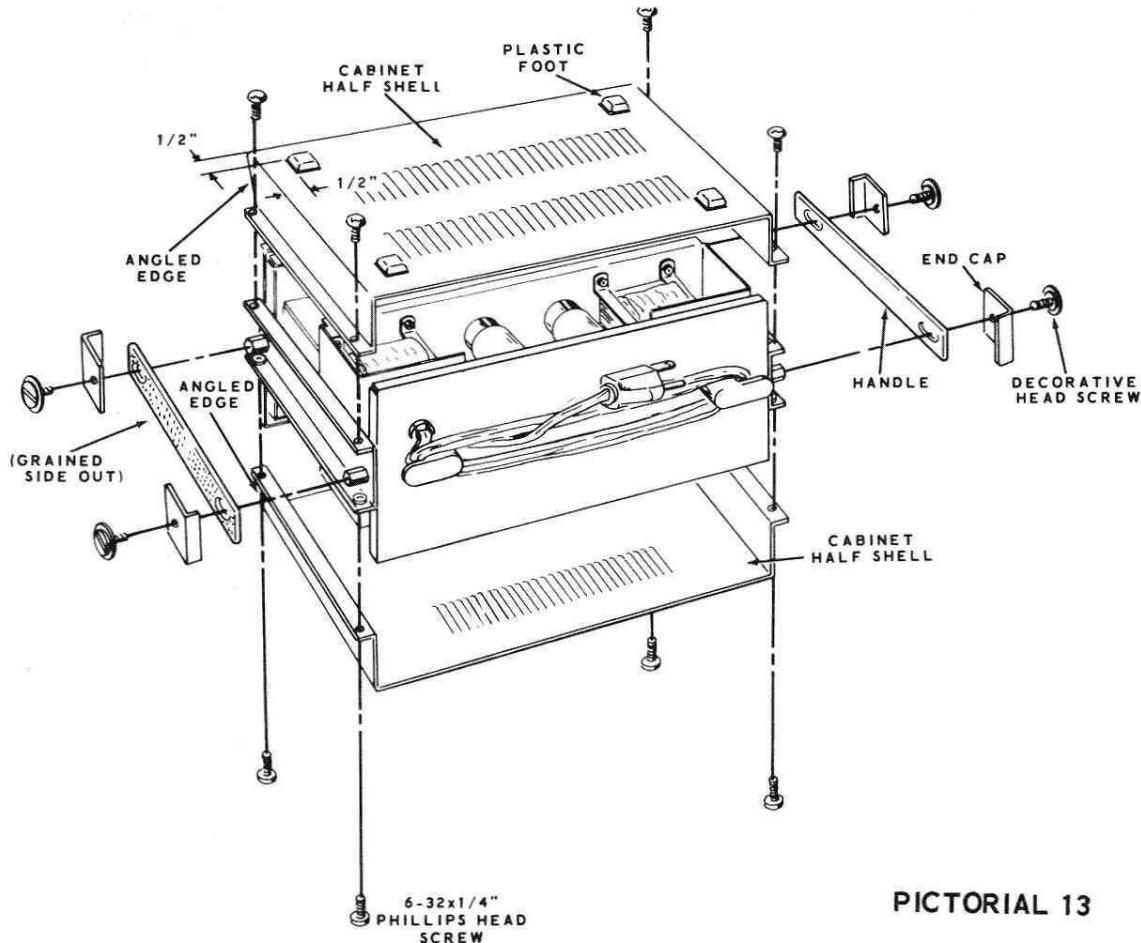

PICTORIAL 13

OPERATION

Refer to Figure 2 which explains the function of the front panel controls. The following two examples show how to use the Regulated High Voltage Power Supply to provide filament, B+, and C- power for a circuit.

EXAMPLE 1

Figure 3 shows the Regulated High Voltage Power Supply being used to provide operating voltages for a tube in a typical RF amplifier stage.

The filament of the tube is connected to the two binding posts marked 6.3 VAC on the Power Supply. The grid return resistor is connected to the white negative (-) binding post to provide the required bias (C-) voltage. The B+ lead is connected to the red positive (+) binding post to provide power for the plate and screen grid of the tube. The common lead should be connected to either COMMON binding post of the Power Supply.

In this circuit application, a jumper wire is normally connected between the GND (ground) and either of the COM (common) binding posts on the Power Supply. This may prevent a shock hazard and will allow additional test equipment to be connected without upsetting any measurements. The jumper wire may not be used during some types of experiments.

With the METER SWITCH in the C- VOLTS position the C- VOLTS control should be adjusted for the desired bias voltage. The VOLTS meter will indicate the bias voltage on the black (0 to 150) scale. With the METER SWITCH in the B+ VOLTS position, the B+ VOLTS control should be adjusted for the desired B+ voltage as indicated on the VOLTS meter red (0 to 400) scale. The MILLIAMPERES meter will indicate the current flowing in the B+ circuit. NOTE: The red triangle at the 100 point on the meter scale indicates the maximum current that can be safely drawn for continuous operation.

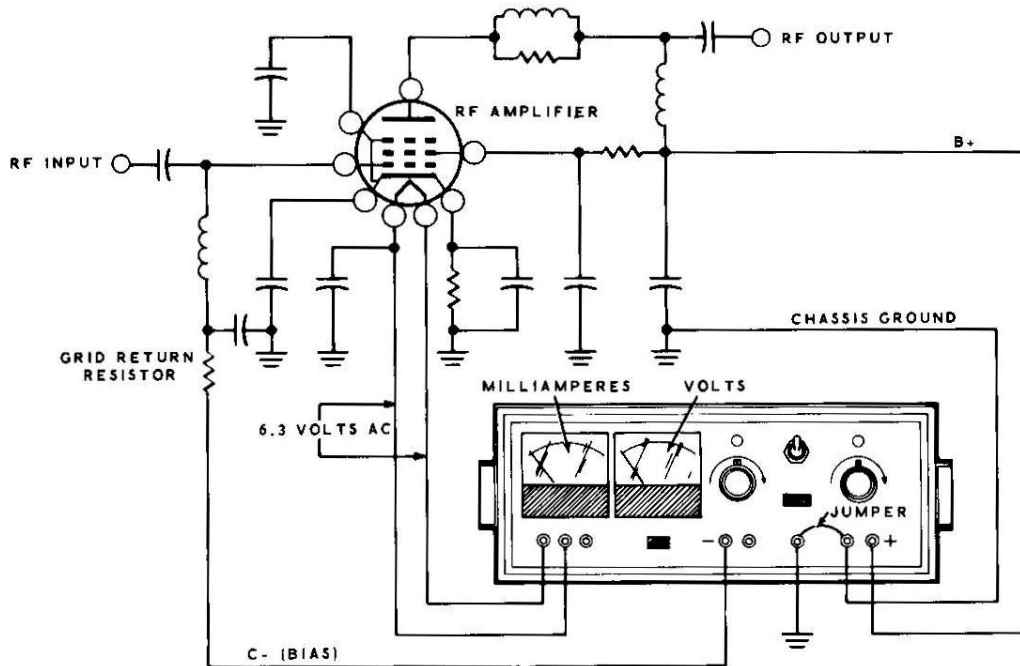

Figure 3

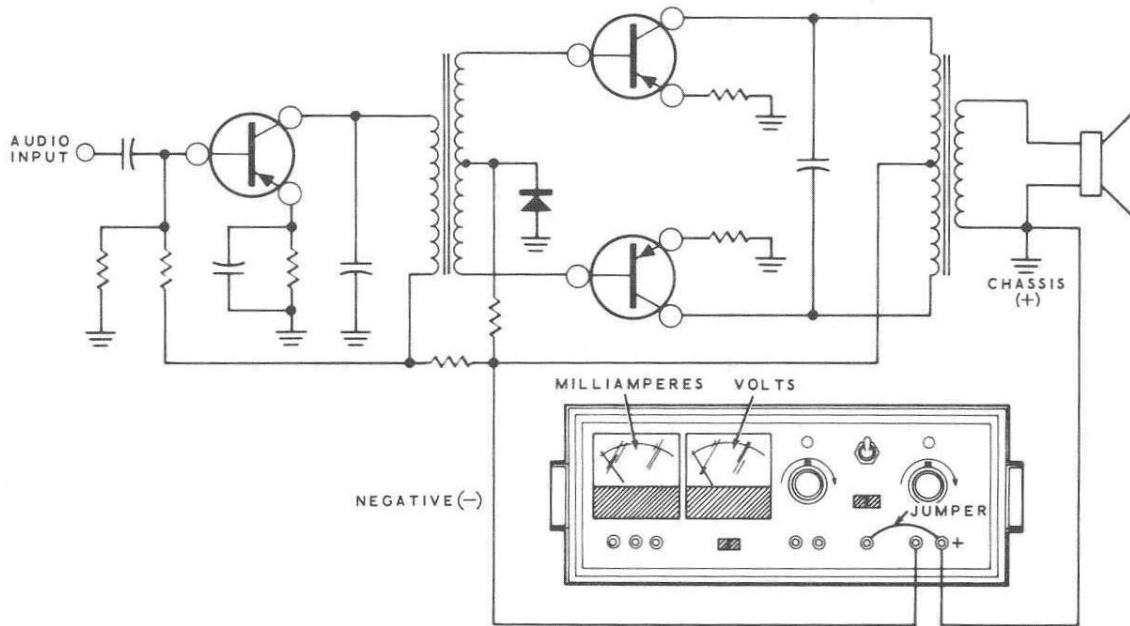

Figure 4

EXAMPLE 2

Figure 4 shows the Regulated High Voltage Power Supply being used to provide operating voltage for a typical transistor audio amplifier. This circuit requires a DC voltage which is negative (-) with respect to the amplifier chassis.

In this application, the red positive (+) binding post on the Power Supply is connected to the

chassis of the audio amplifier. The COM (common) binding post is connected to the negative (-) lead of the amplifier. A jumper wire may be connected between the red positive (+) binding post and the black GND binding post. The chassis of the amplifier and the Power Supply will now be at the same potential. With the METER SWITCH in the B+ VOLTS position, the B+ VOLTS control should be adjusted for the required supply voltage. Note that the current flow in the amplifier circuit would be indicated by the MILLIAMPERES meter.

BIBLIOGRAPHY

Several good reference books are available which contain helpful information on the theory, design, and application of regulated power supplies. A few of these publications are listed here.

THE RADIO AMATEUR'S HANDBOOK, American Radio Relay League.

Gottlieb, DESIGN AND OPERATION OF REGULATED POWER SUPPLIES, Howard W. Sams, Indianapolis.

Smith, RADIOTRON DESIGNERS HANDBOOK, Published by RCA.

IN CASE OF DIFFICULTY

1. Recheck the wiring. Trace each lead in colored pencil on the Pictorial as it is checked. It is frequently helpful to have a friend check your work. Someone who is not familiar with the unit may notice something consistently overlooked by the builder.
2. About 90% of the kits that are returned for repair do not function properly due to poor connections and soldering. Therefore, many troubles can be eliminated by reheating all connections to make sure they are soldered as described in the Soldering section of the Kit Builders Guide.
3. Check to be sure that all tubes are in their proper locations. Make sure that all tubes light up properly.
4. Check the tubes with a tube tester or by substitution of tubes of the same types which are known to be good.
5. Check the values of the parts. Be sure the proper parts have been wired into the circuit, as shown in the pictorial diagrams and as called out in the wiring instructions.
6. Check for bits of solder, wire ends, or other foreign matter which may be lodged in the wiring.
7. If, after careful checks, the trouble is still not located and a voltmeter is available, check voltage readings against those shown on the Schematic Diagram. NOTE: All voltage readings were taken with an 11 megohm input vacuum tube voltmeter. Voltages may vary as much as 20%.
8. A review of the Circuit Description may also prove helpful in indicating where to look for the cause of trouble.

NOTE: In an extreme case where you are unable to resolve a difficulty, refer to the "Customer Service" information inside the rear cover of the Manual. Your Warranty is located inside the front cover.

Troubleshooting Chart

DIFFICULTY	POSSIBLE CAUSE
Neither panel lamp will light.	<ol style="list-style-type: none"> 1. Line cord plug not inserted into AC outlet. 2. Open fuse. 3. Incorrect wiring of METER SWITCH.
Panel lamp on, filaments do not light.	<ol style="list-style-type: none"> 1. Incorrect filament wiring. 2. Incorrect filament transformer primary wiring. 3. Defective filament transformer.
Voltage regulator tubes V1 and V2 do not glow.	<ol style="list-style-type: none"> 1. DC ON-STANDBY switch not in ON position. 2. Check or replace tube V4. 3. Check capacitors C4 and C5 for correct installation (wrong polarity).
No B+ voltage at red + binding post with any setting of B+ VOLTS control.	<ol style="list-style-type: none"> 1. Check diodes D1 through D6. 2. Check capacitors C1A, C1B, C2, and C3. 3. Check tubes V5 and V6. 4. Open Milliampere meter (M2).
B+ voltage too high, cannot be controlled.	<ol style="list-style-type: none"> 1. Check tube V3. 2. Check tubes V5 and V6. 3. Check adjustment of 400 VOLT ADJUST and ZERO VOLTAGE ADJUST controls.
B+ voltage too low, cannot be controlled.	<ol style="list-style-type: none"> 1. Check tube V4. 2. Check adjustment of 400 VOLT ADJUST and ZERO VOLTAGE ADJUST controls.
Poor regulation of B+ voltage.	<ol style="list-style-type: none"> 1. Check tubes V1, V2, V3, V5, and V6.
No C- voltage.	<ol style="list-style-type: none"> 1. Check tube V4. 2. Check capacitors C4 and C5 for correct installation (wrong polarity).



SPECIFICATIONS

B+ VOLTS OUTPUT

Voltage.	0 to 400 volts DC, regulated.
Current.	0 to 100 ma continuous; 125 ma intermittent.
Regulation.	Output variation less than 1% from no load to full load for output of 100 to 400 volts DC. Output variation less than $\pm 1\%$ for a $\pm 10\%$ variation of the 115 volt or 230 volt AC input source.
Ripple.	Less than 10 millivolts RMS ripple, jitter and noise.
Output Impedance.	Less than 10 Ω from DC to 1 MHz. (See Representative Output Impedance Curves.)

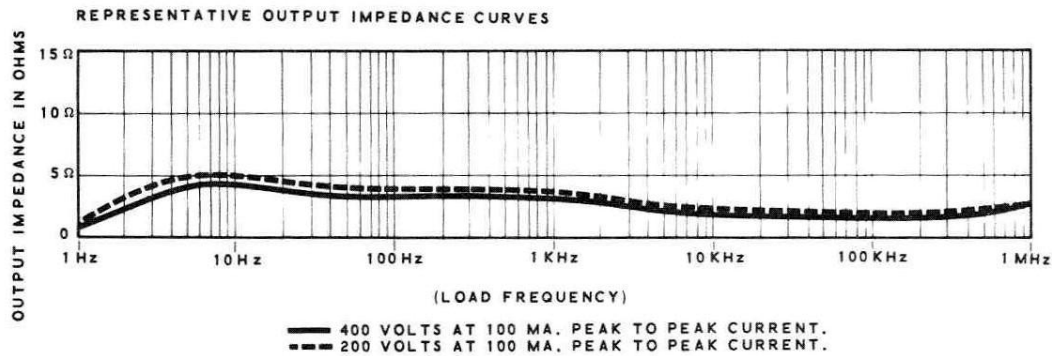

C- AND FILAMENT VOLTS OUTPUT

C- Volts.	0 to -100 volts DC at 1 ma.
Filament Voltage.	6.3 volts AC at 4 amperes, or 12.6 volts AC at 2 amperes.

NOTE: The 6.3 volt and 12.6 volt AC outputs may be used at the same time provided the total combined power does not exceed 25 volt -amperes.

GENERAL

Output Binding Posts.	Common and + (B+ voltage). Common and - (C- voltage). 6.3 VAC at 4 amperes. 12.6 VAC at 2 amperes. Chassis Ground.
Front Panel Controls.	AC Power switch. DC On-Standby switch. Voltmeter switch. C- volts control. B+ volts control.
Circuit Board Controls.	Zero Voltage Adjust. 400 Volt Adjust.
Meters:	
Volts, Dual Scale.	0 to 400 and 0 to 150 volts DC (accuracy: $\pm 3\%$ of full scale).
Milliamperes.	0 to 150 ma (accuracy: $\pm 2\%$ of full scale).
Tube And Diode Complement.	1 - 6BH6, control amplifier. 1 - 6X4, C- rectifier. 2 - 6L6GC series regulators. 2 - OA2, voltage regulators. 6 - Silicon diodes.
Power Requirements.	105 - 125 volts or 210 - 250 volts, 50/60 Hz AC. 150 watts maximum.
Fuse.	1.5 ampere (105-125 VAC operation). NOTE: A 1.0 ampere fuse (not supplied with the kit) is recommended for 210-250 VAC opera- tion.
Dimensions.	13-3/8" wide, 11-1/4" deep, 5-1/2" high.
Net Weight.	16 lbs.

The Heath Company reserves the right to discon-
tinue instruments and to change specifications at
any time without incurring any obligation to in-
corporate new features in instruments pre-
viously sold.

CIRCUIT DESCRIPTION

Refer to the Schematic (fold-out from Page 39) and to the Block Diagram while reading the Circuit Description.

The Heathkit Regulated High Voltage Power Supply is a power source that allows the B+ current to vary over a wide range (from 0 to 100 ma depending on the load) and still maintain the output voltage at its original value.

High B+ voltage is supplied by a full-wave voltage doubler circuit consisting of diodes D3, D4, D5, D6, and capacitors C2 and C3. This high B+ voltage is applied to the plate of the two pentode, series regulator tubes, V5 and V6. The cathodes of V5 and V6 are connected to the positive (+) output binding post through milliammeter M2.

Pentode operation is superior to triode operation in most wide range series regulator applications because there is a lower voltage drop across a pentode than there is across a triode. To allow V5 and V6 to operate as pentodes, a separate built-in power supply is used to provide screen grid voltage for V5 and V6. This supply uses silicon diodes D1 and D2 in a half-wave rectifier circuit followed by C1A, R1, and C1B as a filter network. The filtered DC voltage from this circuit is applied through parasitic suppressor resistors R2 and R3 to the screen grids of series regulator tubes V5 and V6.

Series regulator tubes V5 and V6 act as a large variable resistor whose effective resistance is controlled by the voltage applied to their control grids. Tube V3 produces this control voltage and operates as a DC voltage feedback amplifier.

B+ volts control R12 is part of a voltage divider network connected between the B+ bus (cathode of V5 and V6) and the regulated negative 300 volt point at pin 7 of regulator tube V1. Adjustment of R12 varies the voltage applied through resistor R9 to the control grid of DC voltage feedback amplifier V3. The value of the voltage developed at the plate of V3 depends upon the voltage that is applied to the control grid of V3 from the arm of R12. The voltage at the plate of V3 is applied through parasitic suppressor resistors R4 and R5 to the control grids of series regulator tubes V5 and V6.

When the output load is removed, the voltage at the cathodes of V5 and V6 will tend to surge upward slightly. Resistor R12 (the B+ volts control) is part of the voltage divider network in this cathode circuit, therefore, a voltage change will be produced at the control grid of tube V3. This control grid voltage will increase slightly and tube V3 will conduct more heavily. This increased conduction will result in a decrease in the voltage at the plate of V3 with a corresponding decrease in voltage at the control grids of V5 and V6. The decrease in control grid voltage will increase the effective resistance of series regulator tubes V5 and V6 and lower the output voltage at the cathodes (B+ bus) of V5 and V6 to the original value set by the B+ volts control.

This means that any variation of the B+ output voltage caused by a change in output load is immediately amplified by voltage feedback amplifier V3 and applied to the control grids of series regulator tubes V5 and V6. This causes a corresponding increase or decrease in the effective resistance of the series regulators and will restore the B+ output voltage to the value originally set by the B+ volts control.

Screen voltage for control amplifier V3 is taken from a voltage divider network consisting of resistors R7 and R8 connected between the + high voltage source and the regulated -150 volt source. The + high voltage varies with line voltage changes. This voltage is taken from the junction of R7 and R8 and applied to the screen grid of control amplifier V3. The resistance values are chosen to provide substantially zero output impedance.

An increase in line voltage and/or a decrease of the output load current will result in a momentary increase in output voltage above the level set by the B+ volts control. A corresponding increase in the resistance of the series regulator circuit of V5 and V6 will occur. This resistance increase will immediately lower the output voltage to its original set value. Conversely, the output voltage will momentarily decrease and then return to its original set value if the line voltage should decrease and/or the output load current increase.

With AC Power switch S1 in the On position and DC On-Standby switch S2 in the Standby position, power is applied only to transformer T2. T2 supplies low voltage AC for the filaments of tubes V3, V4, V5, V6, and 6.3 volts and 12.6 volts AC for external filament circuits connected to the filament binding posts. Power is also applied by switch S1 to the red or amber panel lamps.

With DC On-Standby switch S2 in the On position, power is applied to high voltage transformer T1. T1 provides high voltage AC for the screen voltage supply, high B+ voltage supply, and the -300 volt C- bias supply. Using separate filament and high voltage transformers allows the high voltage DC circuit to be switched to the Standby position, removing all DC high voltages from the equipment or circuits under test or development. The filament of the tubes in the Power Supply and in the external circuits remain in a normal operating condition.

CHASSIS PHOTOGRAPH

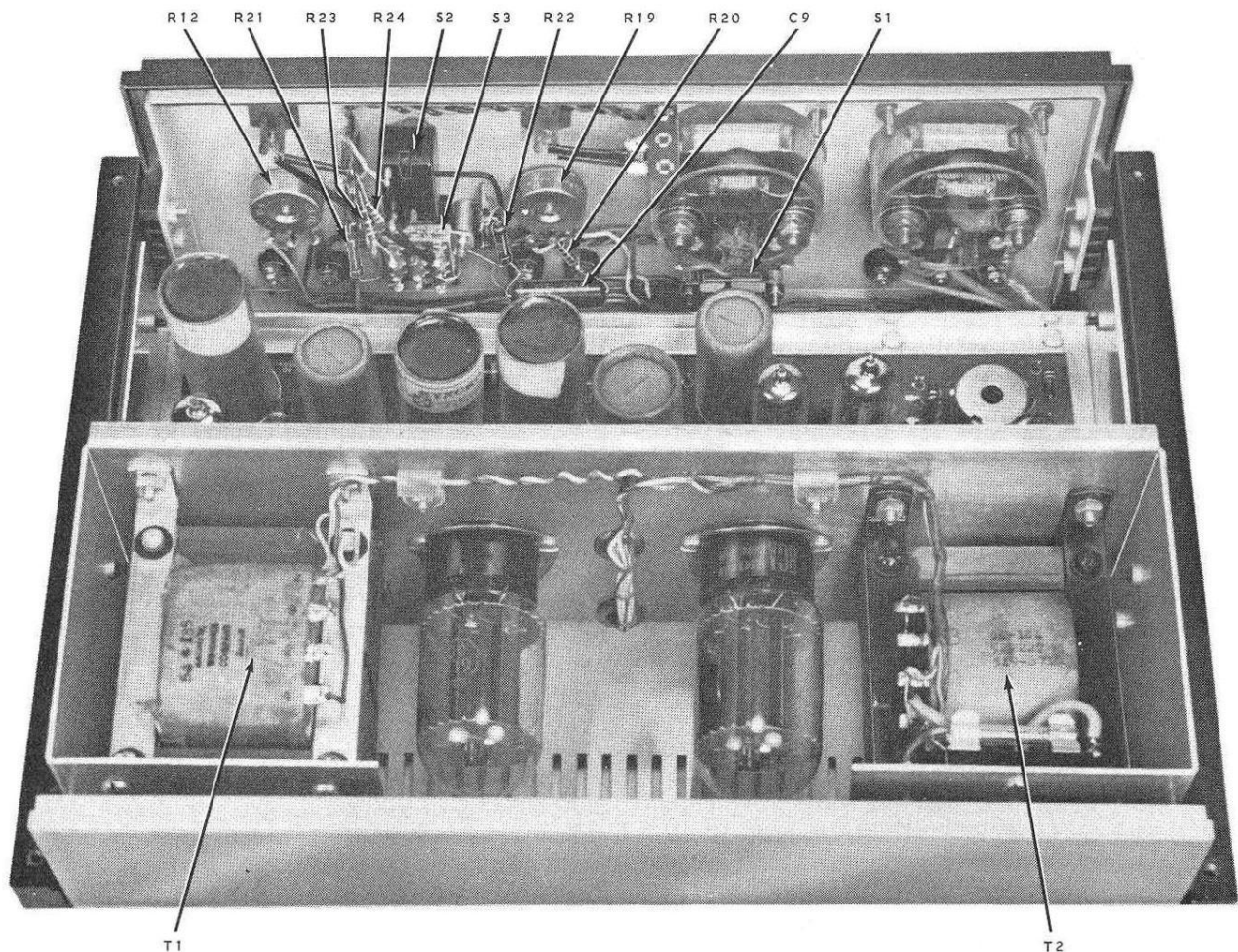

REPLACEMENT PARTS PRICE LIST

To order parts, use the Parts Order Form furnished with this kit. If a Parts Order Form is not available, refer to "Replacement Parts" in the "Kit Builders Guide."

PART No.	PRICE Each	DESCRIPTION
----------	------------	-------------

RESISTORS

1/2 Watt

1-3	.10	100 Ω
1-9	.10	1000 Ω
1-22	.10	22 K Ω
1-23	.10	27 K Ω
1-27	.10	150 K Ω
1-99	.15	240 K Ω
1-33	.10	470 K Ω
1-106	.15	680 K Ω 5%
1-35	.10	1 megohm

1 and 2 Watt

1-27-1	.10	33 K Ω , 1 watt
1-14-2	.20	1500 Ω , 2 watt
1-6-2	.20	27 K Ω , 2 watt

1/2 Watt Precision

2-86	.20	150 K Ω
2-138	.20	400 K Ω

CAPACITORS

Electrolytic

25-270	1.20	2 x 20 μ fd, 350 V
25-182	1.20	70 2fd, 350 V
25-158	.85	20 μ fd, 450 V
25-183	1.05	40 μ fd, 450 V

Other Capacitors

23-59	.20	.05 μ fd tubular
27-37	.20	.056 μ fd Mylar
27-34	.25	.2 μ fd Mylar

CONTROLS-SWITCHES

10-216	.55	50 K Ω control
10-257	.50	500 K Ω control
10-162	.60	200 K Ω control
10-218	.50	500 K Ω miniature control
60-24	.55	SPST rocker switch
60-34	.85	TPDT rocker switch
61-9	1.20	SPST toggle switch

PART No.	PRICE Each	DESCRIPTION
----------	------------	-------------

HARDWARE

#6 Hardware

250-229	.05	6-32 x 1/4" phillips head screw
250-89	.05	6-32 x 3/8" screw
250-270	.05	6-32 x 3/8" screw (black)
250-26	.05	6-32 x 5/8" screw
250-227	.05	6-32 x 7/8" phillips head screw
250-535	.25	6-32 decorative screw
250-365	.05	#6 x 1/4" sheet metal screw
250-304	.15	6-32 x 7/16" spacer stud
252-3	.05	6-32 nut
254-1	.05	#6 lockwasher
259-1	.05	#6 solder lug
255-15	.05	#6 x 1/2" spacer

#8 Hardware

250-137	.05	8-32 x 3/8" screw
252-4	.05	8-32 nut
254-2	.05	#8 lockwasher
259-2	.05	#8 solder lug
259-24	.05	#8 wire clamp

Other Hardware

252-7	.05	Control nut
253-10	.05	Control flat washer
254-4	.05	Control lockwasher
252-32	.05	Push-on speednut
207-37	.10	Tube retainer
259-20	.05	Circuit board terminal

TUBES-DIODES-LAMPS

411-8	4.40	6L6GC tube
411-59	1.35	OA2 tube
411-64	.80	6X4 tube
411-95	1.40	6BH6 tube
57-27	.60	Silicon diode
412-15	.15	NE-2H lamp



PART No.	PRICE Each	DESCRIPTION
----------	------------	-------------

TERMINAL STRIPS-SOCKETS

431-14	.10	2-lug terminal strip
431-51	.10	2-lug terminal strip
431-35	.10	7-lug terminal strip
434-129	.15	7-pin socket
434-58	.25	8-pin socket

BINDING POSTS-KNOBS

100-16-2	.10	Black binding post cap
100-16-18	.10	Red binding post cap
100-534	.10	White binding post cap
100-641	.10	Brown binding post cap
427-3	.15	Binding post base
75-17	.10	Binding post insulator
462-245	.25	Knob
455-50	.10	Knob bushing

METAL PARTS

210-35	3.45	Bezel
90-357-2	3.05	Cabinet half-shell
200-488	1.85	Transformer chassis
200-489	1.00	Circuit board chassis
203-482-1	1.65	Front panel
203-483-1	1.30	Rear panel
204-759-1	.10	End cap
204-776-1	.90	Siderail

METERS-TRANSFORMERS

407-123	8.85	Voltmeter
407-124	8.40	Milliammeter
54-184	4.50	Filament transformer
54-185	7.80	Power transformer

PART No.	PRICE Each	DESCRIPTION
----------	------------	-------------

HARNESS-WIRE-SLEEVEING

134-155	2.15	Wiring harness
89-23	.80	Line cord
344-50	.05/ft	Black hookup wire
344-52	.05/ft	Red hookup wire
344-56	.05/ft	Blue hookup wire
346-1	.05	Sleeving

MISCELLANEOUS

73-45	.10	Grommet
75-30	.25	Strain relief
75-71	.10	Strain relief
85-174-1	2.15	Circuit board
207-5	.10	Cable clamp
211-34	.50	Handle strap
261-28	.10	Plastic foot
261-30	.10	Line cord retainer
413-10	.10	Red lens
413-14	.30	Amber lens
421-25	.30	1.5 ampere slow-blow fuse
422-1	.25	Fuseholder
490-5	.10	Nut starter
331-6	.15	Solder
	2.00	Manual (See front cover for part number.)

The above prices apply only on purchases from the Heath Company where shipment is to a U.S.A. destination. Add 10% (minimum 25 cents) to the price when ordering from a Heathkit Electronic Center to cover local sales tax, postage and handling. Outside the U.S.A. parts and service are available from your local Heathkit source and will reflect additional transportation, taxes, duties and rates of exchange.

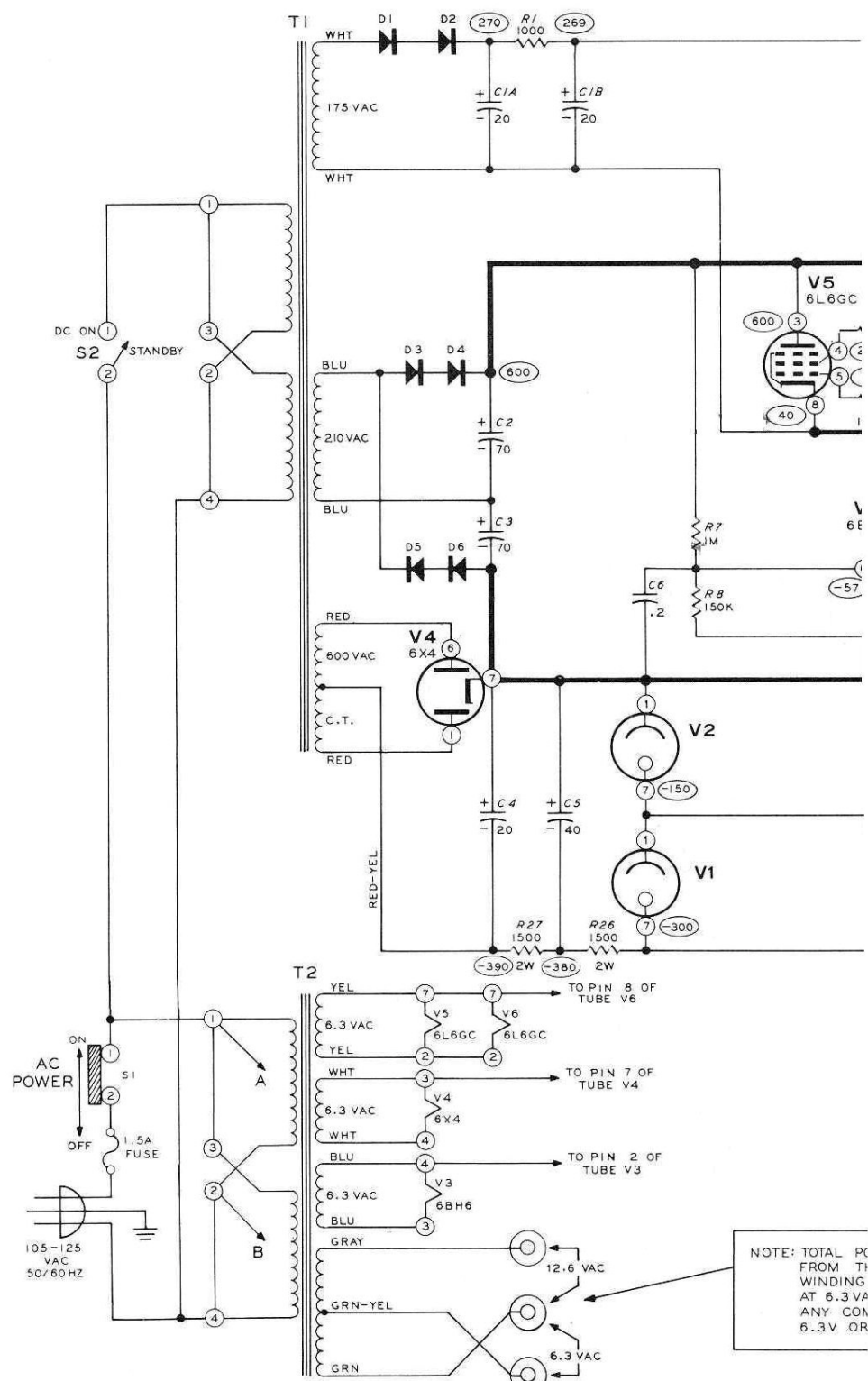
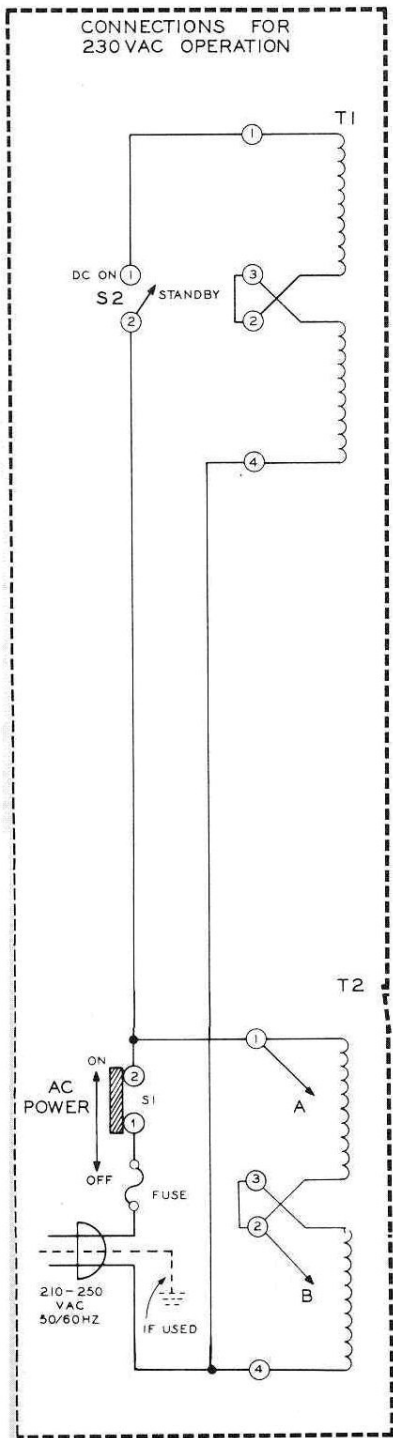

NOTE: TOTAL P.C. FROM T1 WINDING AT 6.3 VA ANY COM 6.3 V. OR

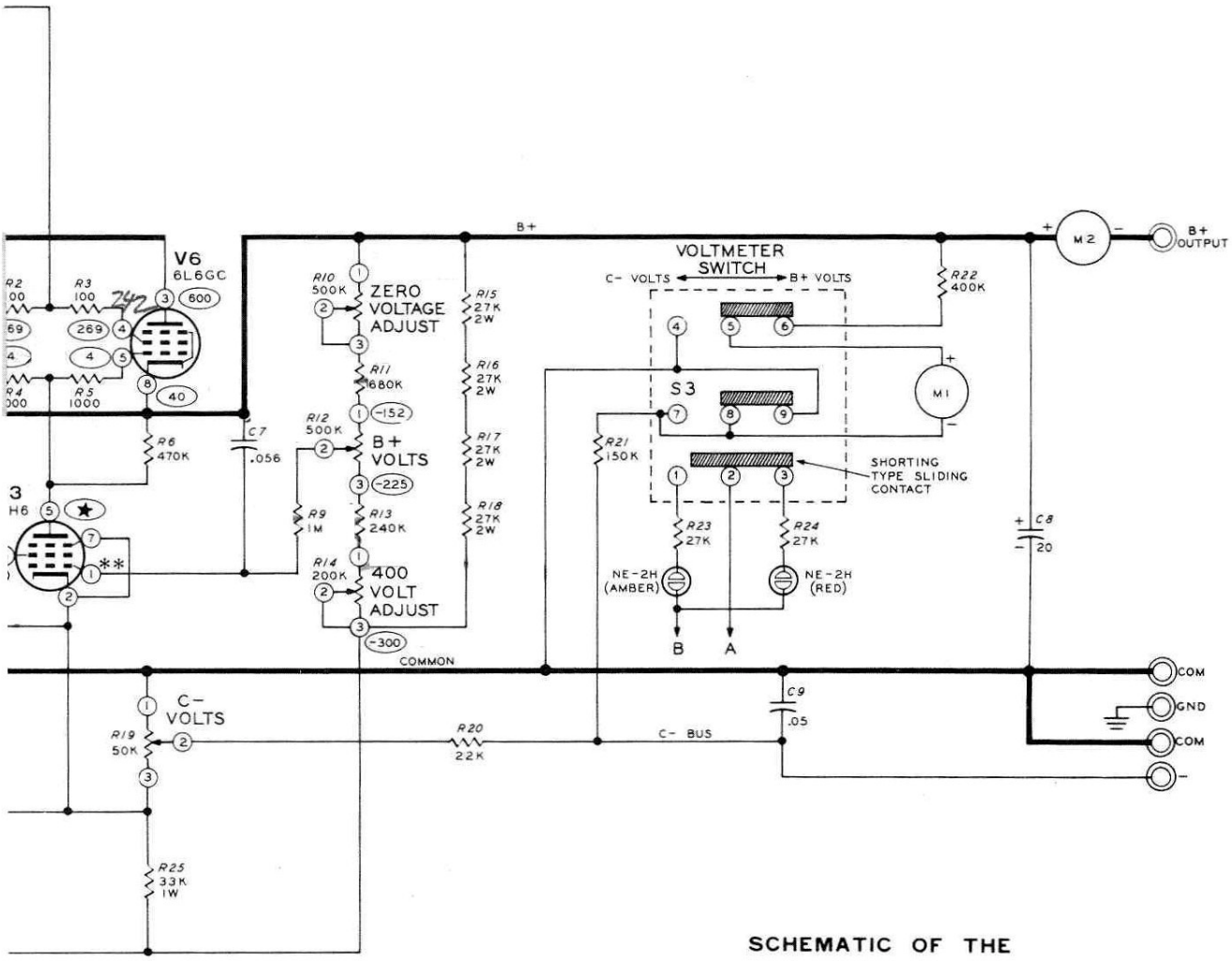

**SCHEMATIC OF THE
HEATHKIT®
REGULATED H V
POWER SUPPLY
MODEL IP-17**

NOTES:

1. ALL RESISTORS ARE 1/2 WATT UNLESS MARKED OTHERWISE. RESISTOR VALUES ARE IN OHMS (K=1000, M=1,000,000).
2. ALL CAPACITOR VALUES ARE IN μ fd.
3. ○ INDICATES DC VOLTAGE MEASURED FROM POINT INDICATED TO EITHER COMMON BINDING POST. VOLTAGE READINGS TAKEN WITH AN 11 MEGOHM INPUT VTVM. VOLTAGE MAY VARY \pm 20%.
4. **DO NOT MEASURE THE VOLTAGE AT PIN 1 OF V3 AS THIS WILL UPSET THE REGULATION OPERATION OF THE TUBE.
5. THE VOLTAGES INDICATED AT TUBES V3, V5 AND V6 ARE OBTAINED WITH THE ZERO VOLTAGE ADJUST CONTROL TURNED FULLY COUNTER-CLOCKWISE AND THE 400 VOLT ADJUST CONTROL TURNED FULLY CLOCKWISE.

IF AVAILABLE
USE TRANSFORMER
IS 25 VOLT AMPERES
C. 12.6 VAC OR
COMBINATION OF
12.6 V.

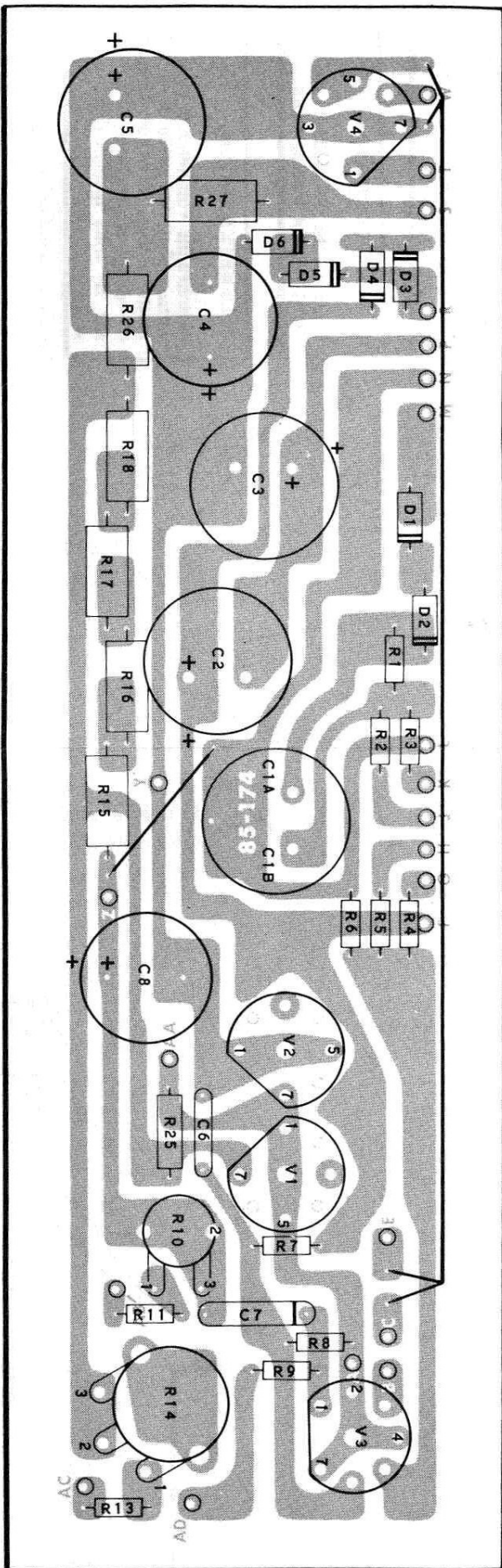

CIRCUIT BOARD X-RAY VIEW

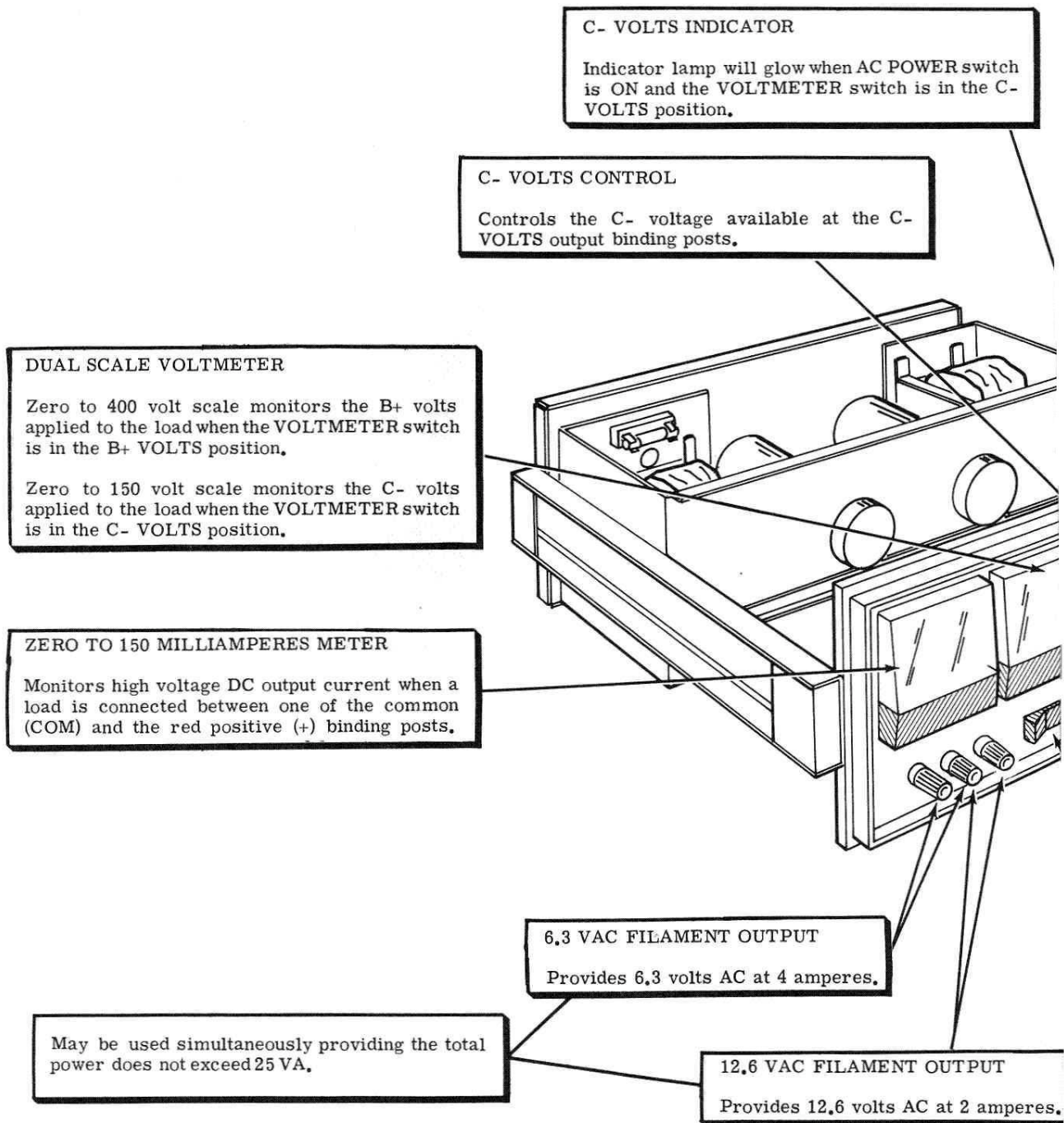

FIGURE 2



DC ON-STANDBY SWITCH

In the DC ON position, this switch applies power to the high voltage transformer in the Power Supply. DC voltage will be present at the appropriate output binding posts. No DC voltage will be present when the switch is in the STANDBY position.

B+ VOLTS INDICATOR

Indicator lamp will glow when AC POWER switch is ON and the VOLTMETER switch is in the B+ position.

B+ VOLTS CONTROL

Controls the B+ voltage available at the B+ VOLTS output binding posts.

VOLTMETER SWITCH

Switches the Voltmeter to read either the output voltage available at the C- output binding posts or the voltage at the B+ output binding posts. C- voltage is indicated on the 0 to 150 volt scale and B+ volts is indicated on the 0 to 400 volt scale.

B+ VOLTS OUTPUT

Provides from 0 to 400 volts of regulated DC at currents up to 100 ma.

CHASSIS GROUND

Allows either common (COM) Power Supply output to be connected to chassis ground.

C- VOLTS OUTPUT

Provides negative voltage from 0 to -100 volts DC up to 1 ma.

AC POWER SWITCH

Turns the AC power on and off. With this switch in the ON position, power is applied to the filament transformer and to the DC ON-STANDBY switch. Filament voltage is thus applied to the tubes in the Power Supply and to the 6.3 and 12.6 volt filament output binding posts.